



**YXZ1000R TIE ROD
INSTALLATION INSTRUCTIONS:**

2016+ YAMAHA YXZ1000R

**PART NUMBER:
10120**

We recommend that installation of all Weller Racing parts be completed by a professional who is experienced in suspension tuning. With proper installation and maintenance, Weller Racing suspension products will provide exceptional performance and durability. For any questions, please contact Weller Racing immediately. We thank you for choosing Weller Racing for your suspension tuning needs!

NEED HELP?

Our representatives are here to help you with any questions concerning the operation of this product.

CALL 480-507-4771

Monday thru Friday 8:00am to 5:00pm MST

RECOMMENDED TOOLS AND SUPPLIES

- General Mechanics Tool Set
- 19mm and 17mm Wrench or Socket
- 10mm Allen Key
- Pliers
- Snap Ring Pliers

PART BREAKDOWN

NOTE: For any OE hardware please refer to OEM service manual for torque specifications. For all included hardware please torque to specifications shown below.

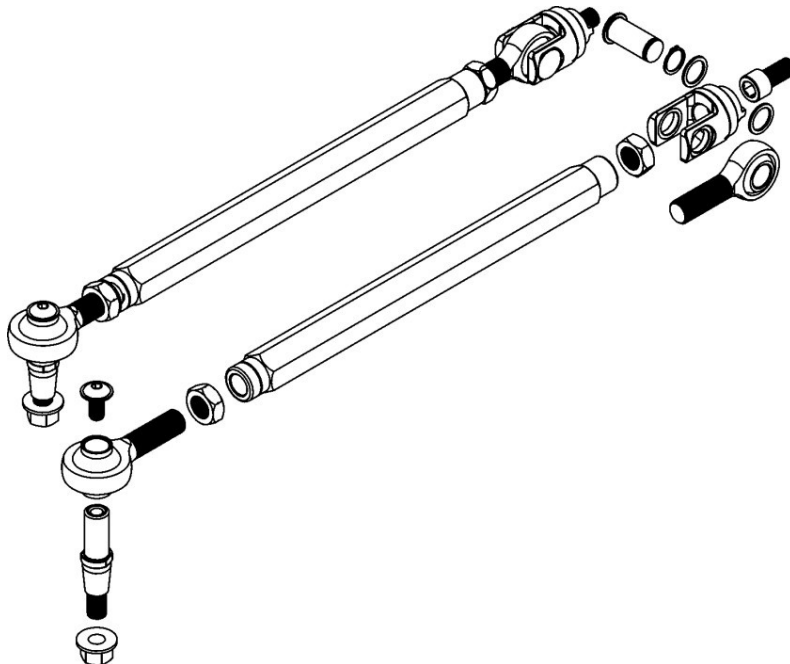

INSTALLATION PROCEDURE

Step 1:

The boot/bellow is secured by two clamps. The small clamp can be removed with pliers without damaging the clamp itself. The larger clamp that holds the boot/bellow in place on the rack end must be cut in order to be removed. Once the clamps are removed, the boot/bellow can be removed as well. Use a flat head screwdriver to pry the boot/bellow on the rack end and pull the boot/bellow towards to the outer tie rod side.

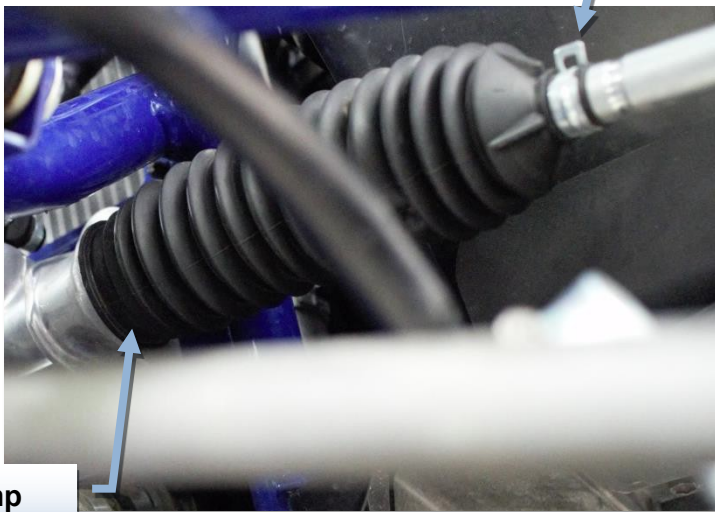
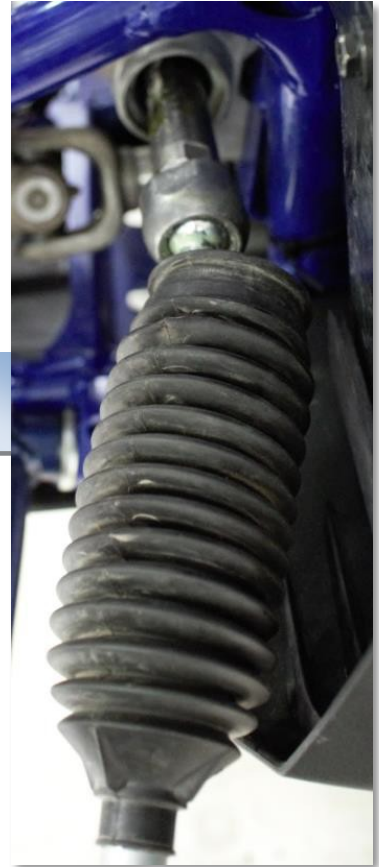

Clamp Location 1

Clamp Location 2

Step 2:

Locate the factory tie rod in front of the vehicle. The outer tie rod is secured by a castle nut. That castle nut should be locked in with a cotter pin. Use pliers to remove the cotter pins from the outer tie rods.

Grab a 19mm wrench or socket and ratchet to loosen the castle nuts holding the outer tie rods.

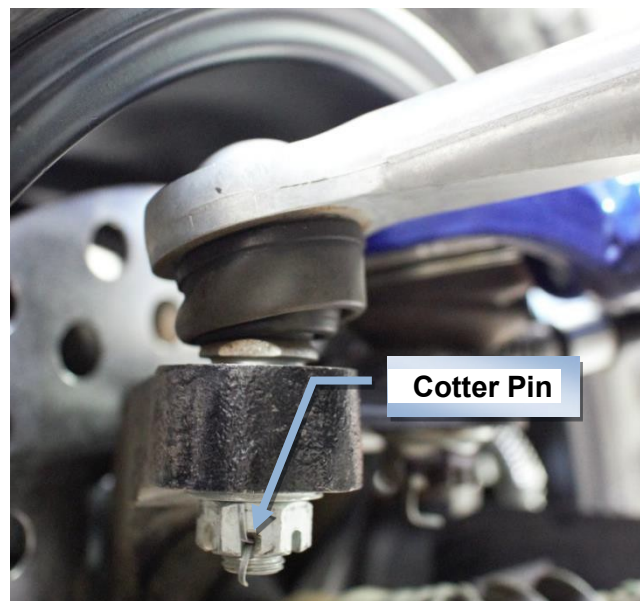

Cotter Pin

Step 3:

Use a mallet or hammer to smack the side of the knuckle to unseat the shank of the outer tie rod. Then after a few hits, a vertical hit on the shank upwards should fully unseat from the knuckle or a ball joint remover as shown.



Step 4:

Before attempting to remove the inner tie rod, first grab a 10mm socket and remove a bolt that holds the liner for more clearance to work.



Step 5:

Grab a 32mm wrench or crescent wrench to loosen the inner tie rod end. There are 4 flats that you should be able to grab on. To have better access to each end, turn the steering wheel to move the rack towards the side you are currently working on. After it's loosened, remove the entire tie rod assembly.



Step 6:

Now the new Weller Racing Tie Rods can be installed. The clevis part must be installed first on the inner rack ends.

Clevises are marked R and L to signify right and left. L = Drivers side. R = Passenger side. Take the clevis and insert the 2 teeth into the slots of the rack end. Check if the clevis is installed as shown.



Next install the supplied M12X1.25 socket head cap screw. Use **lots of red Loctite** on the threads of the bolt and then screw the bolt into rack to secure the clevis piece. **Torque the bolt to 72 ft-lbs.**

Step 7: Next grab the rod end (right hand thread heim joint). Insert the clevis pin to hold the rod end in the clevis. To secure the clevis pin, use snap ring pliers and the supplied snap rings to lock it in place.



Step 8: The factory boot/bellow can be reinstalled. Slide the boot/bellow over the current assembly. Then fasten the RH 5/8" jam nut on the rod end.

Optional

Reuse the factory clamp to hold the boot/bellow in place.

Do **NOT** cut the boot. The OEM Boot will fit over the Rod End.



Step 9:

Fasten the rest of the tie rod onto the right hand 5/8" rod end. Afterward insert the shank into the knuckle.



Step 10:

Next use a rubber mallet to seat the shank into the knuckle.

Apply anti-seize to the external threads of the shank before fastening the supplied lock nuts.

Then grab a 18mm wrench or a crescent wrench to hold the shank steady to tighten the supplied lock nuts. The lock nut requires a 17mm wrench or socket.



Step 11:

Use standard zip ties or the OEM band clamps to secure the boot on to the steering rack.

Tip: Turn the wheel to compress the boot/bellow on the steering rack.



ROD END ADJUSTMENT GUIDELINES

When adjusting rod end to desired position, adjust so that the rod end and adjuster have approximately the same amount of thread showing. Always use the jam nuts to secure the rod end and adjuster. Never tighten the rod end into the adjuster or the adjuster in the lower control arm as a jamming mechanism.

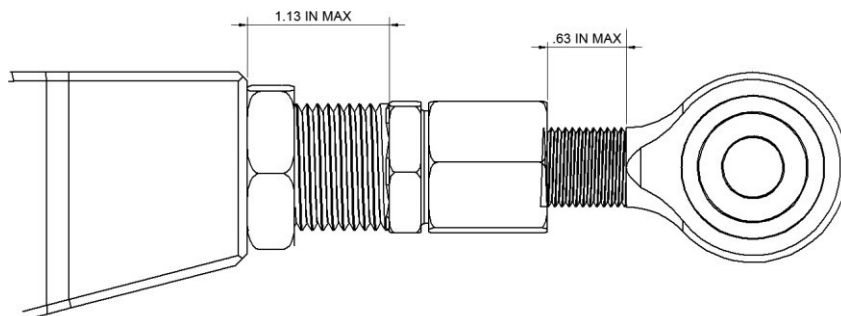

CORRECTLY ADJUSTED

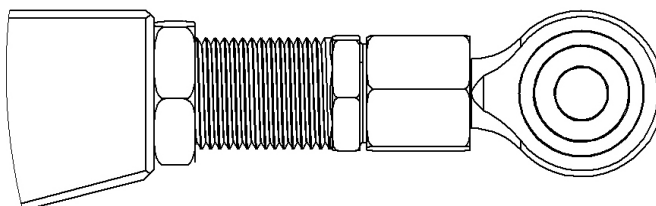

INCORRECTLY ADJUSTED
INSUFFICIENT THREAD ENGAGEMENT ON ADJUSTER

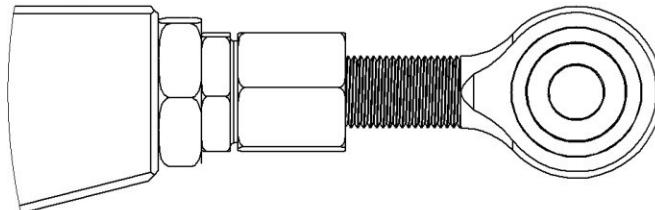

INCORRECTLY ADJUSTED
INSUFFICIENT THREAD ENGAGEMENT ON ROD END

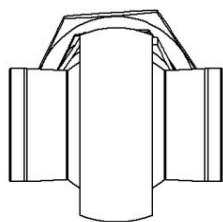

CORRECTLY POSITIONED

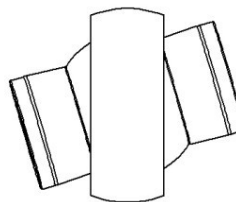

INCORRECTLY POSITIONED
TOO MUCH STATIC ROD END MISALIGNMENT

 **WARNING**

High performance parts. For off-road use only. Installation should be carried out by a qualified facility. Improper use or installation may result in injury or death.



Weller Racing LLC.
3200 N Delaware St.
Chandler, AZ 85225
Ph: 480.507.4771
Fax: 480.467.4202
sales@wellerracing.com