



**ASSAULT**  
INDUSTRIES



## INSTALLATION INSTRUCTIONS

FEBK-CA-X3: STRUCTURAL REINFORCEMENT KIT

- ▲ MAKE SURE THE MODEL ON THE INSTRUCTION SHEET MATCHES YOUR VEHICLE.
- ▲ DO NOT DISCARD PACKAGING UNTIL PRODUCT HAS BEEN SUCCESSFULLY INSTALLED.

- ▲ BE SURE TO READ ALL INSTRUCTIONS AND ILLUSTRATIONS BEFORE STARTING.

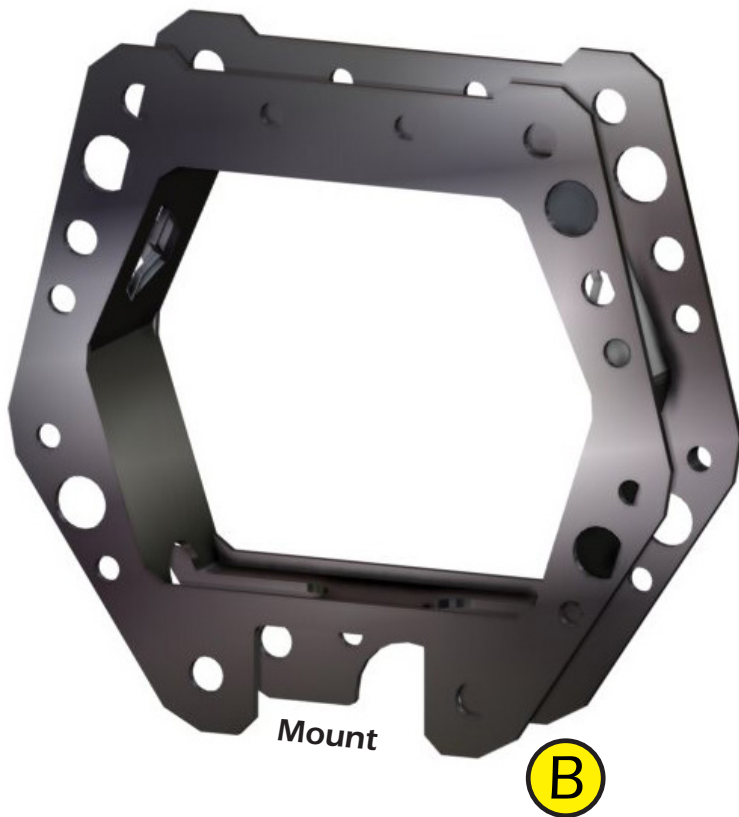

**NOTE: Keep all components removed from machine**

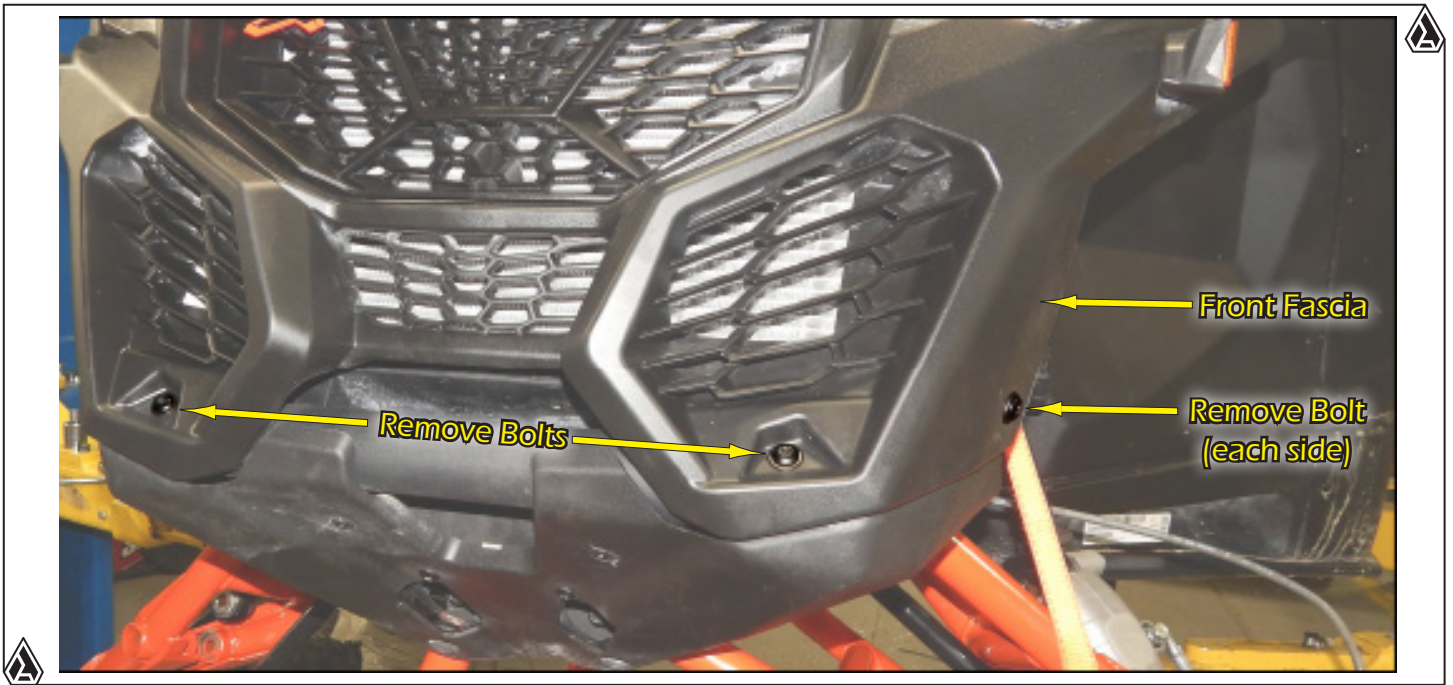

1. Remove hardware shown from Front Fascia. See Fig. 1.

FIG.1

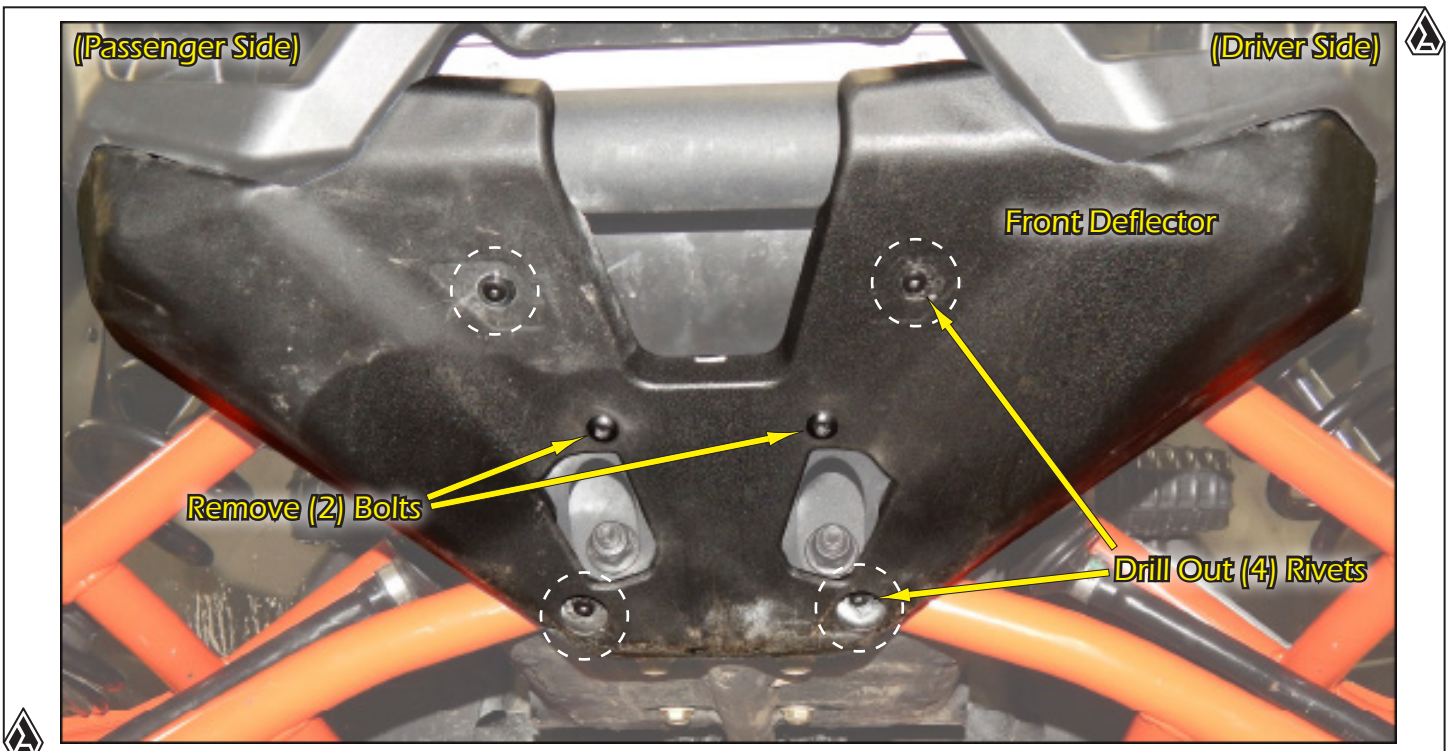

2. Remove Front Deflector. See Fig.2.

FIG.2



3.Remove stock Bulkhead from machine. See Fig.3.

FIG.3

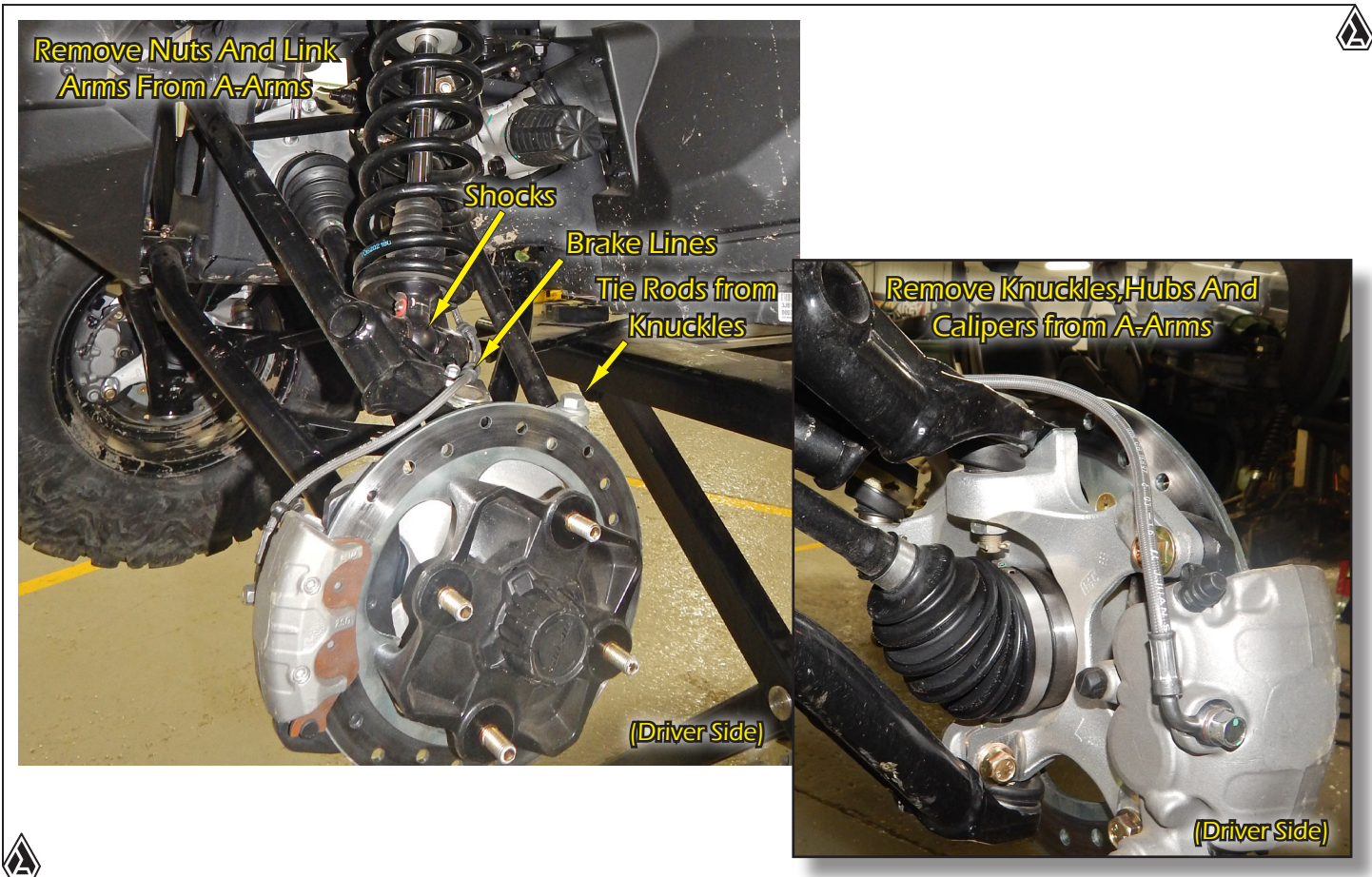

4.Remove Shocks, Braklines and Tie Rods from A-Arm as described in Fig.4.

FIG.4



5. Remove hardware from Shroud as shown in Fig.5.

FIG.5

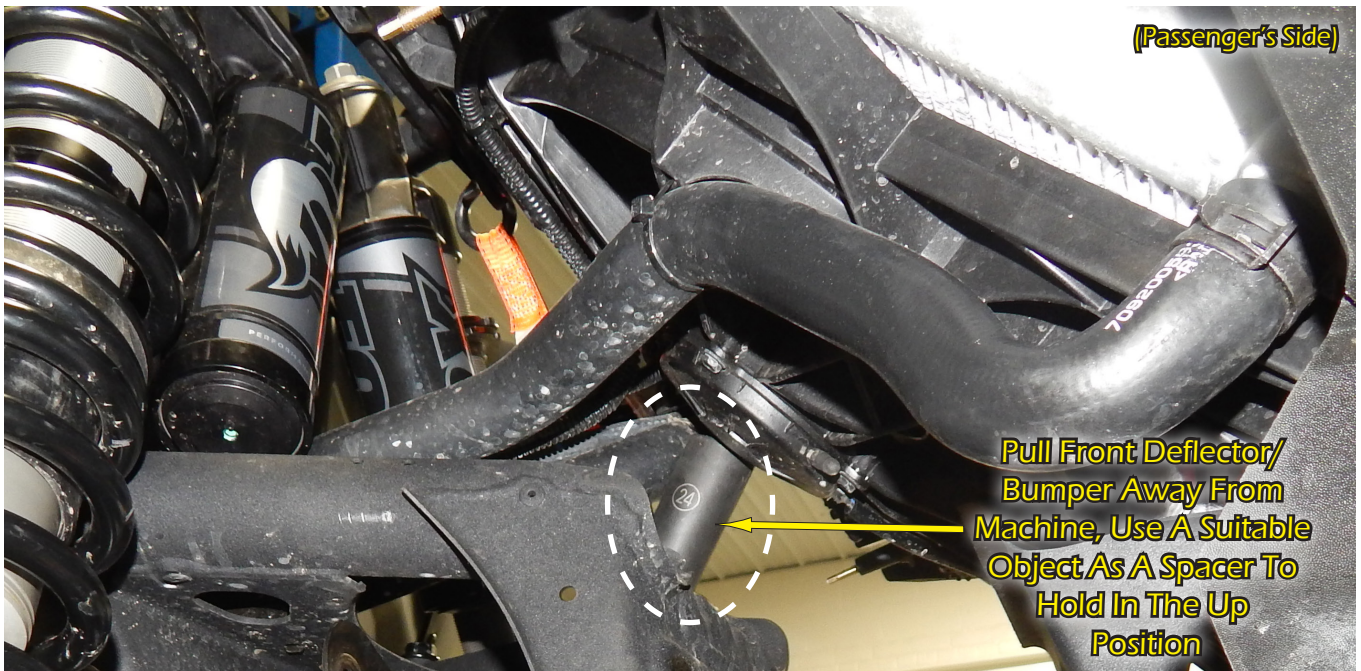

6. Remove A-Arms from machine. See Fig.6.

FIG.6

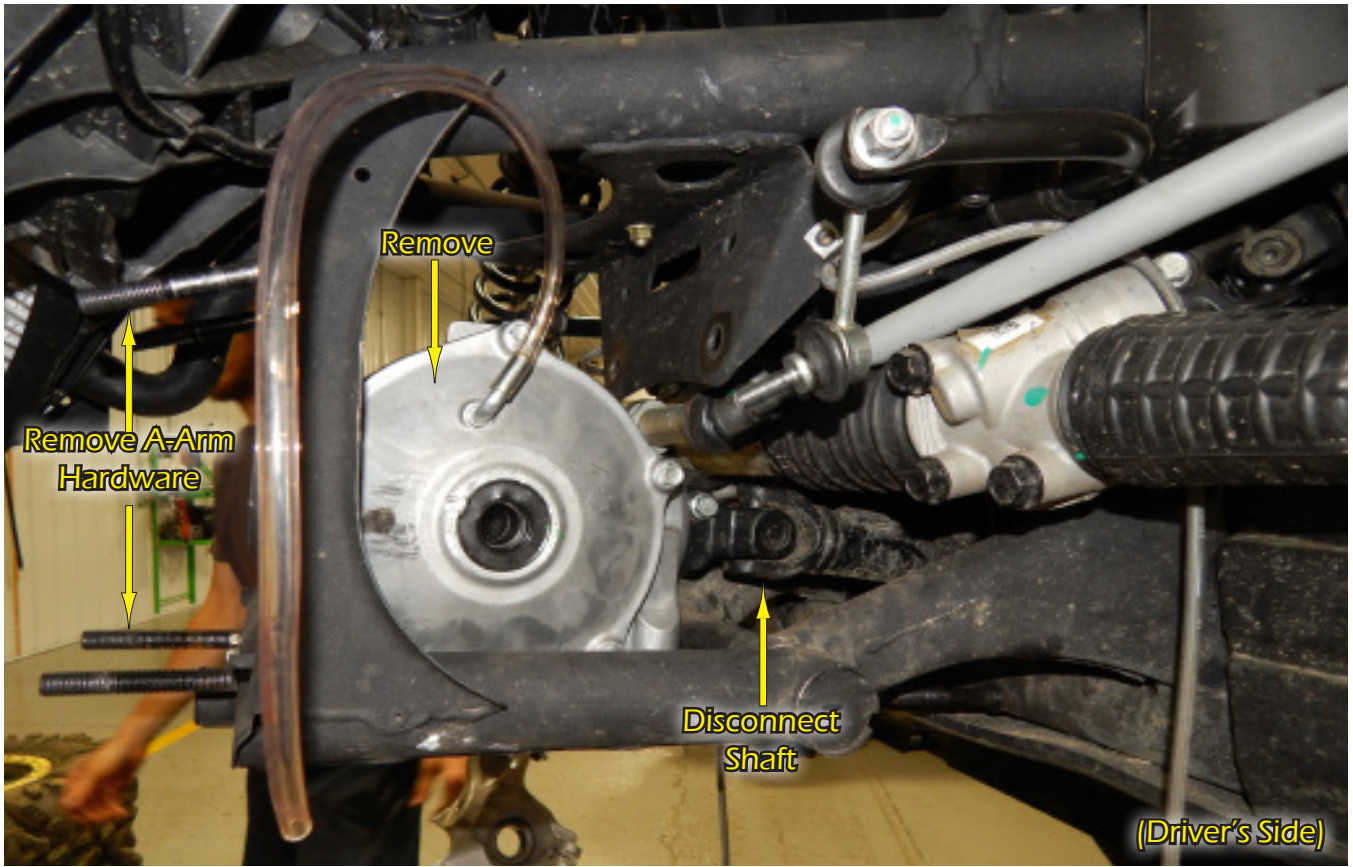

7. Remove Axles, Front Differential, and Hardware as shown in Fig.7.

FIG.7

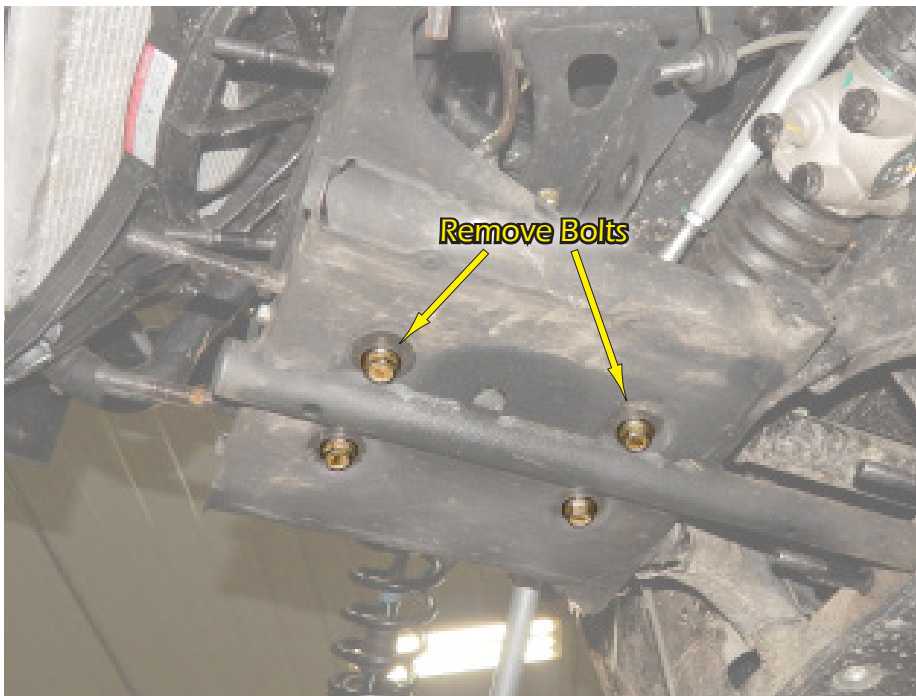

8. Remove four (4) bolts as shown in Fig.8.

FIG.8



9. If present, remove stock Lower Radiator Deflector from machine. See Fig.9.

FIG.9



**REINSTALL FRONT DIFFERENTIAL AND AXLES RIGHT BEFORE UPPER BRACE (C) IS INSTALLED**

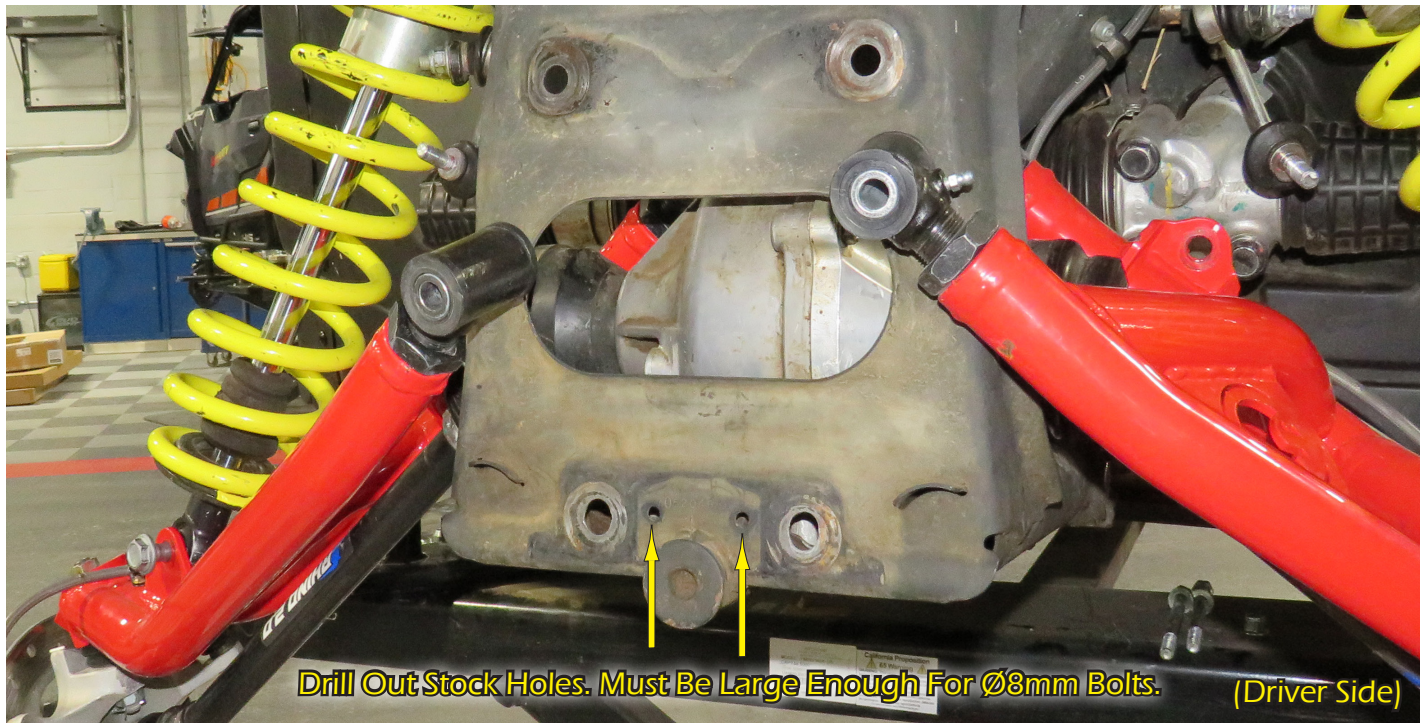

Drill Out Stock Holes. Must Be Large Enough For Ø8mm Bolts. (Driver Side)

FIG.9

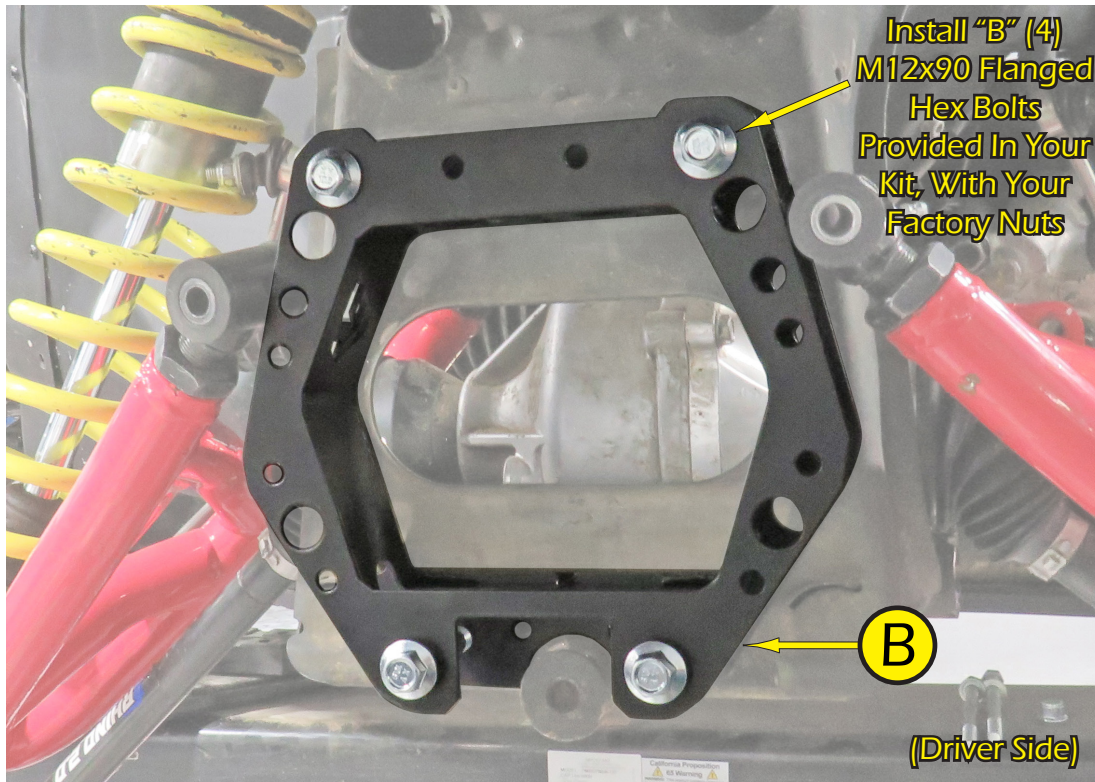

Install "B" (4) M12x90 Flanged Hex Bolts Provided In Your Kit, With Your Factory Nuts

**B**

(Driver Side)

10. Install Mount (B) with hardware shown. Hardware should be snug but not tight. See Fig.10.

FIG.10

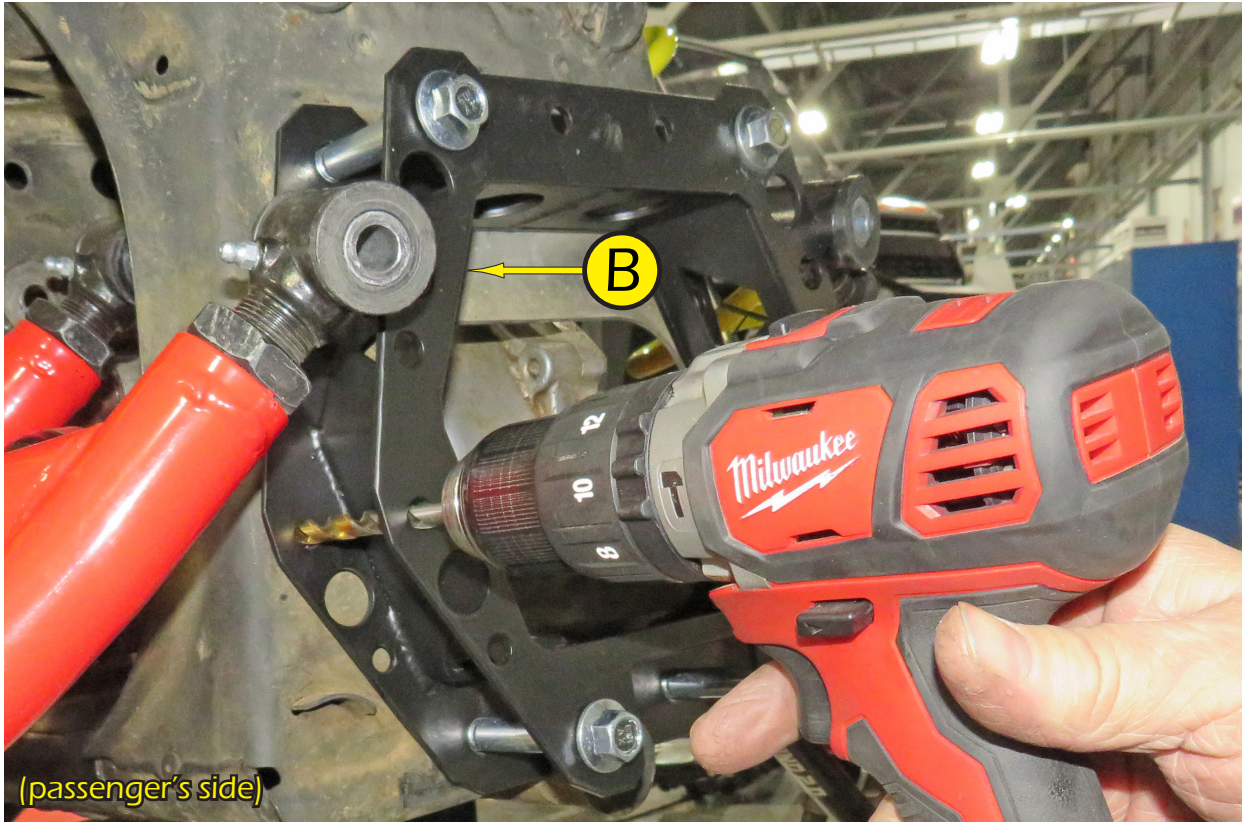

11. Drill (4) holes through Frame. Holes must be large enough for Ø8mm bolts. See Fig.11.

FIG.11

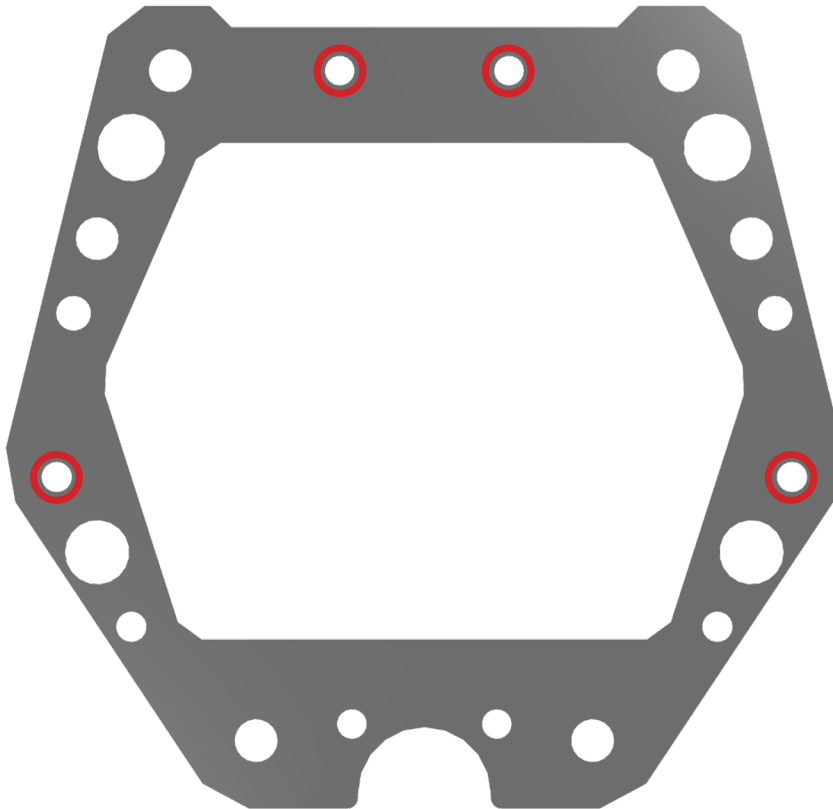

**NOTE:** Use (4) highlighted holes in Mount (B) as a guide.

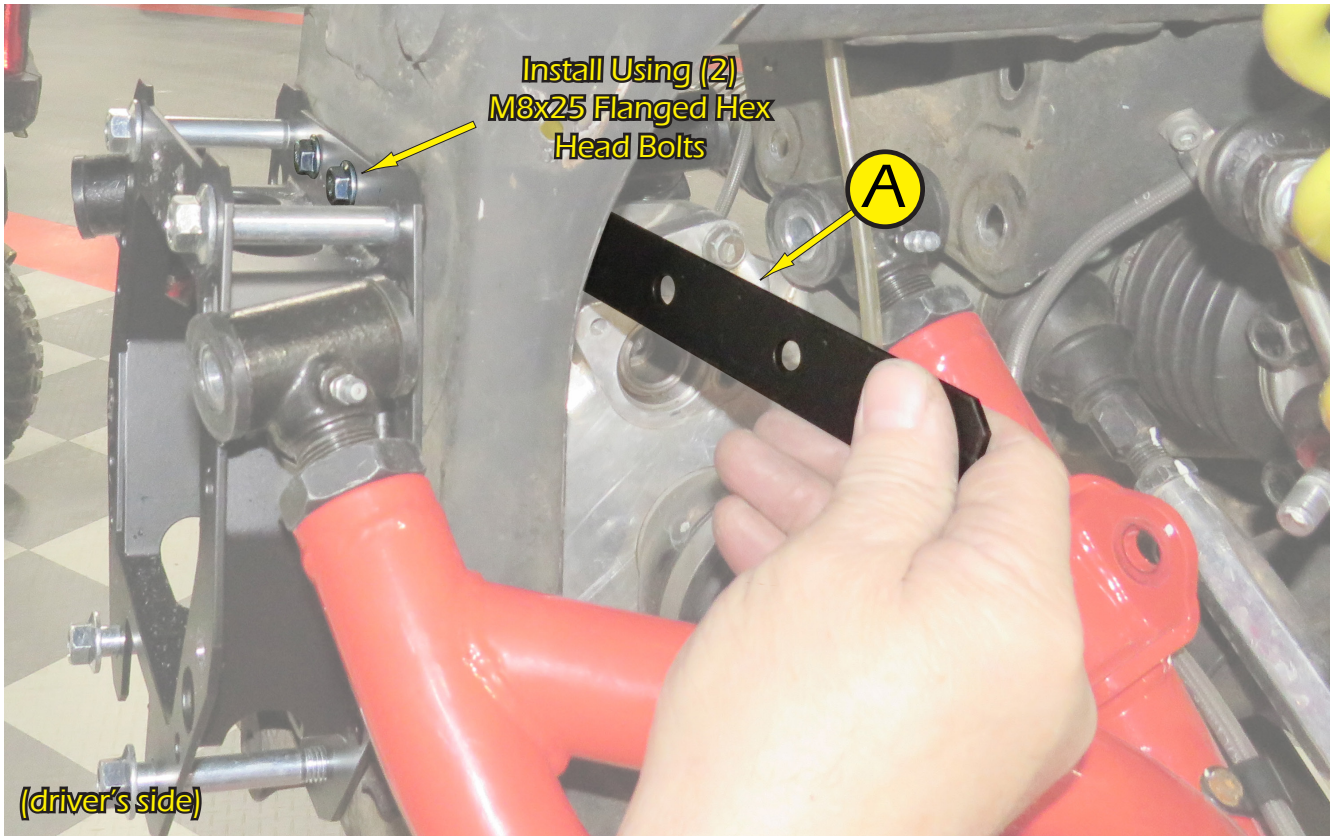

12. Install Mount Using (2) M8x25 Flanged Hex Head Bolts. See Fig.12.

FIG.12

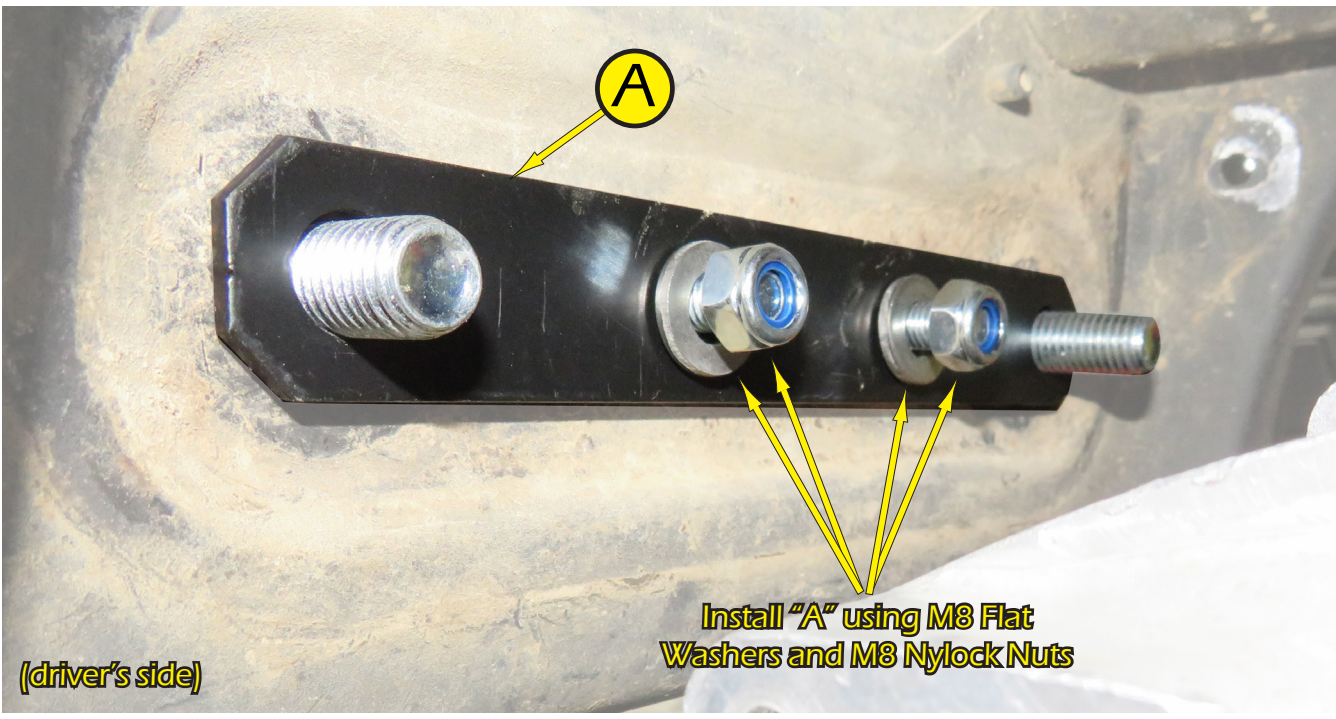

13. Then install Upper Plate to those bolts using M8 Flat Washers and M8 Nylock Nuts. Hardware should be snug but not tight. See Fig.13.

FIG.13

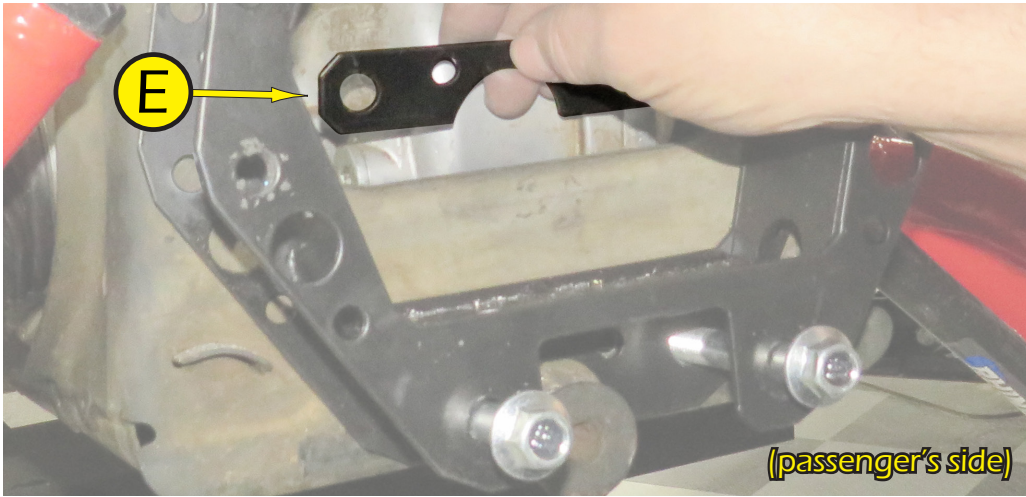

FIG.14A

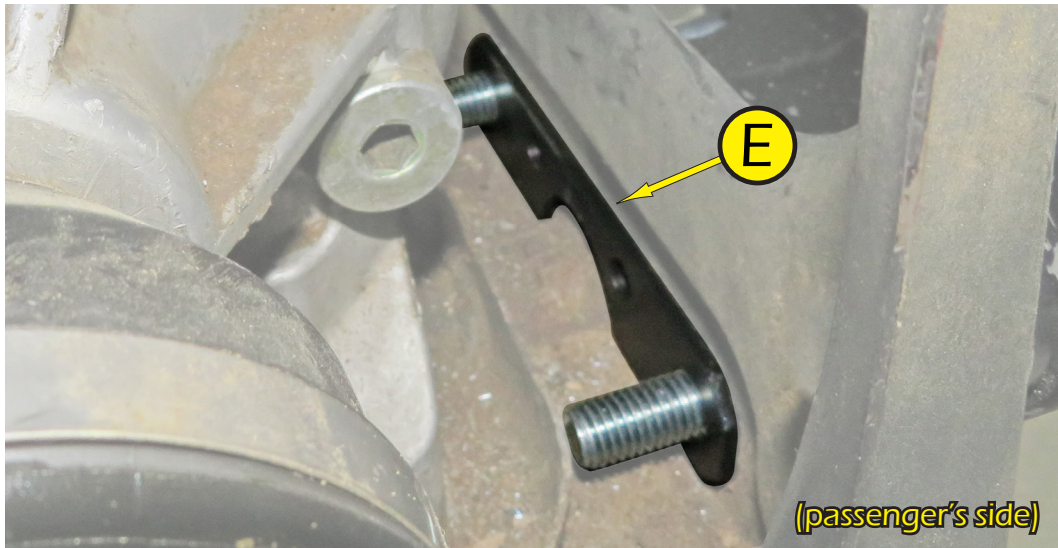

FIG.14B

14. Place Lower Plate (E) onto previously installed M12 Bolts. See Fig.14A-B.



FIG.15

15. Secure Lower Plate (E) with hardware shown. Hardware should be snug but not tight.

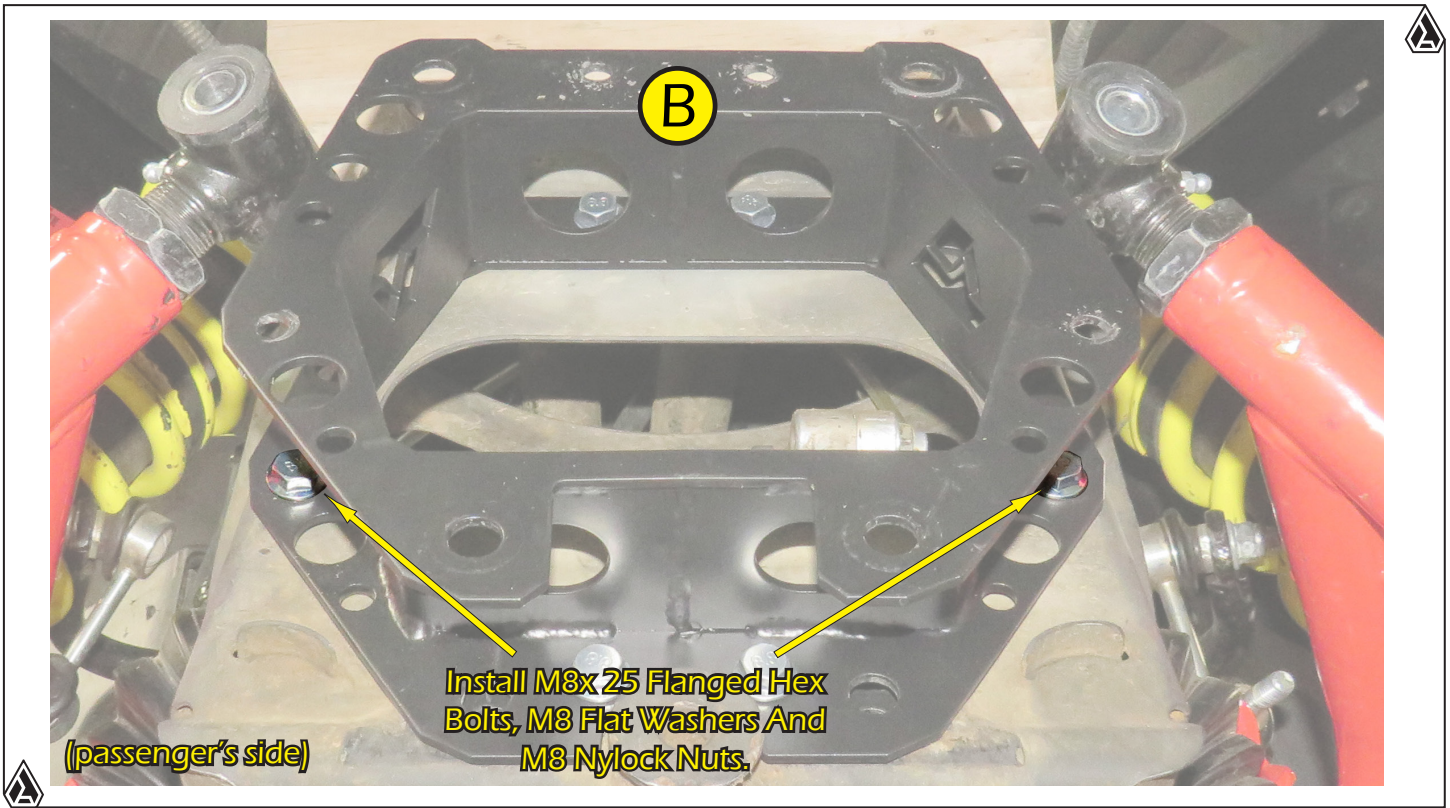

16. Secure **Mount (B)** with hardware shown. Hardware should be snug but not tight. See **Fig. 16**. FIG. 16



17. Remove previously installed M12 hardware. Tighten all M8 hardware.

## REINSTALL FRONT DIFFERENTIAL AND AXLES

Install **Upper Brace (C)** with hardware shown and tighten secure. See **Fig. 17**.

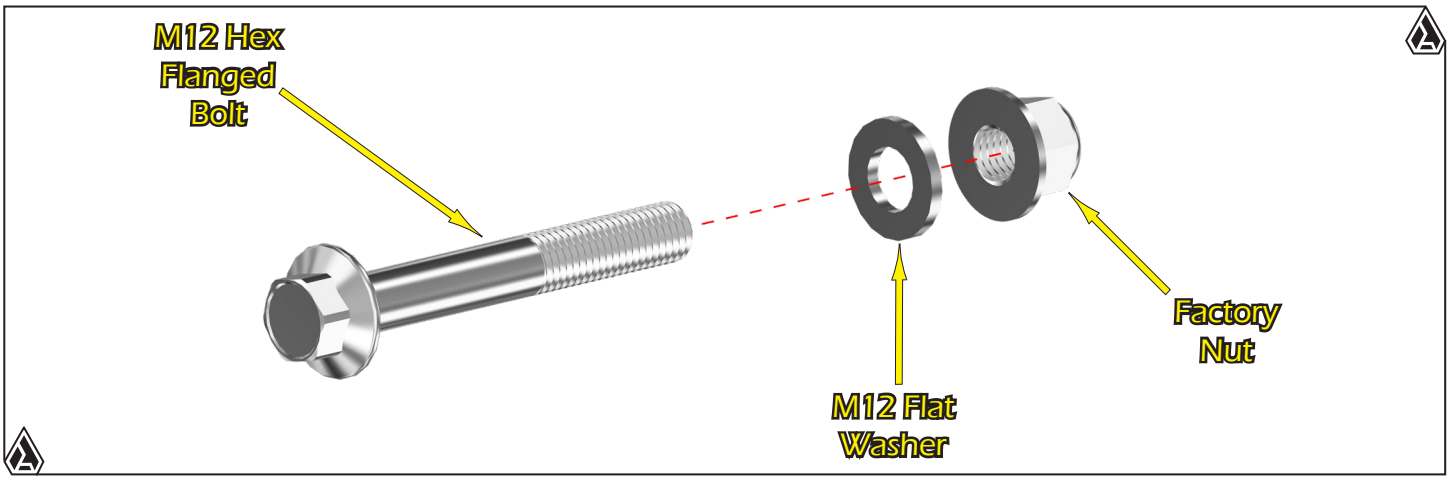

18. When securing A-Arms, follow setup shown. See Fig. 18.

FIG. 18

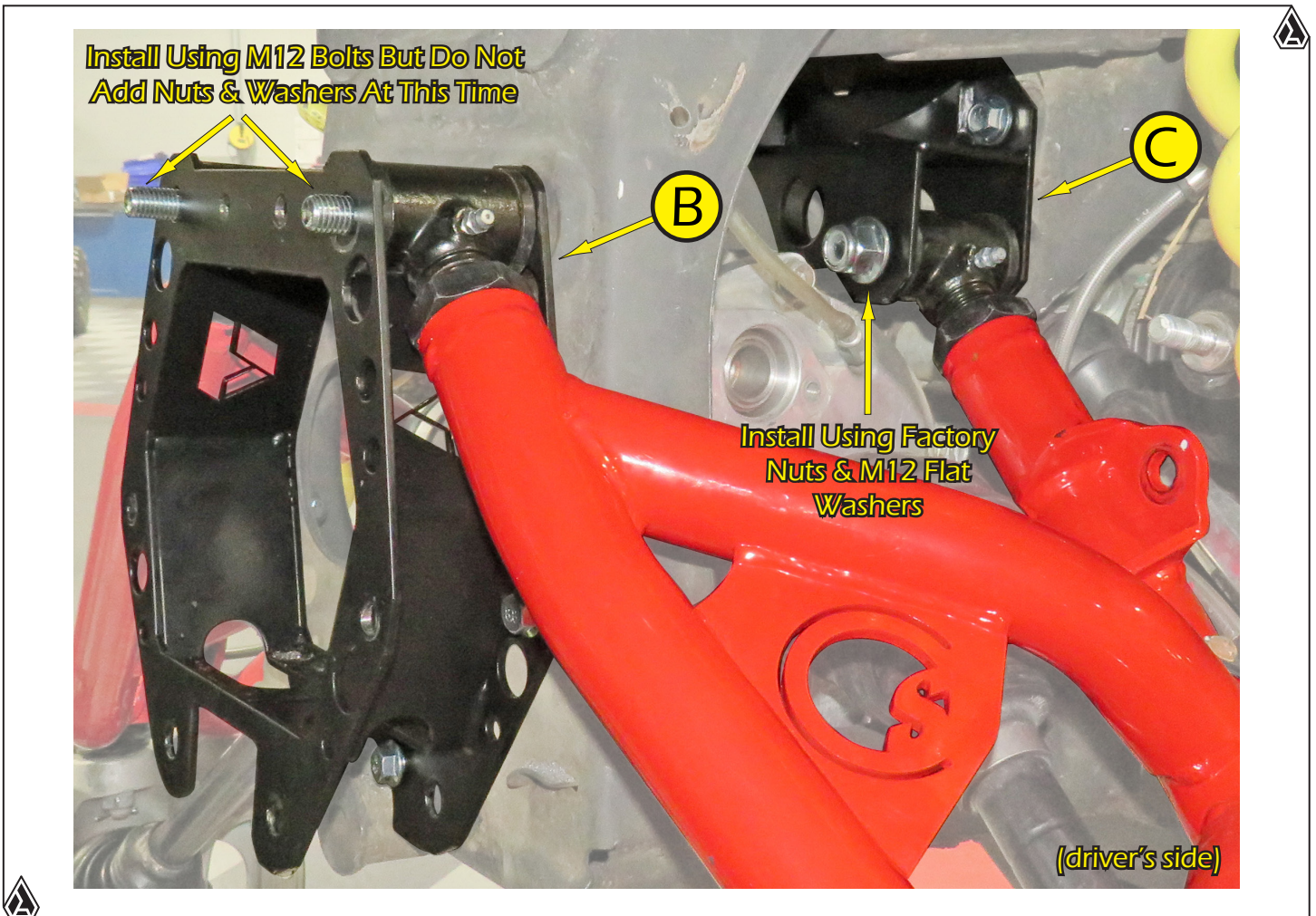

19. Secure Upper A-Arms with M12 Bolts but do not add washers and nuts at this time.

FIG. 19

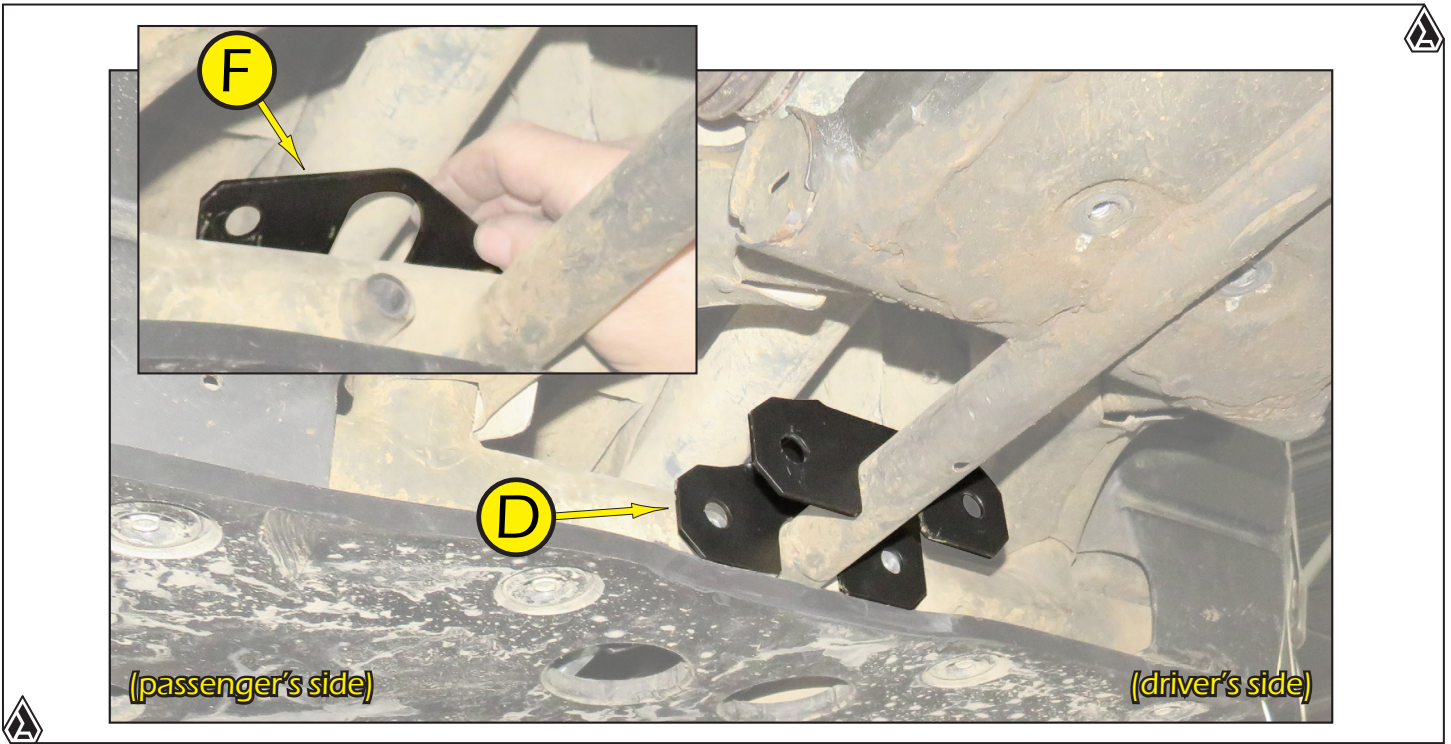

20. Install Lower Brace (D) and Shear Plate (F). See Fig.20.

FIG.20

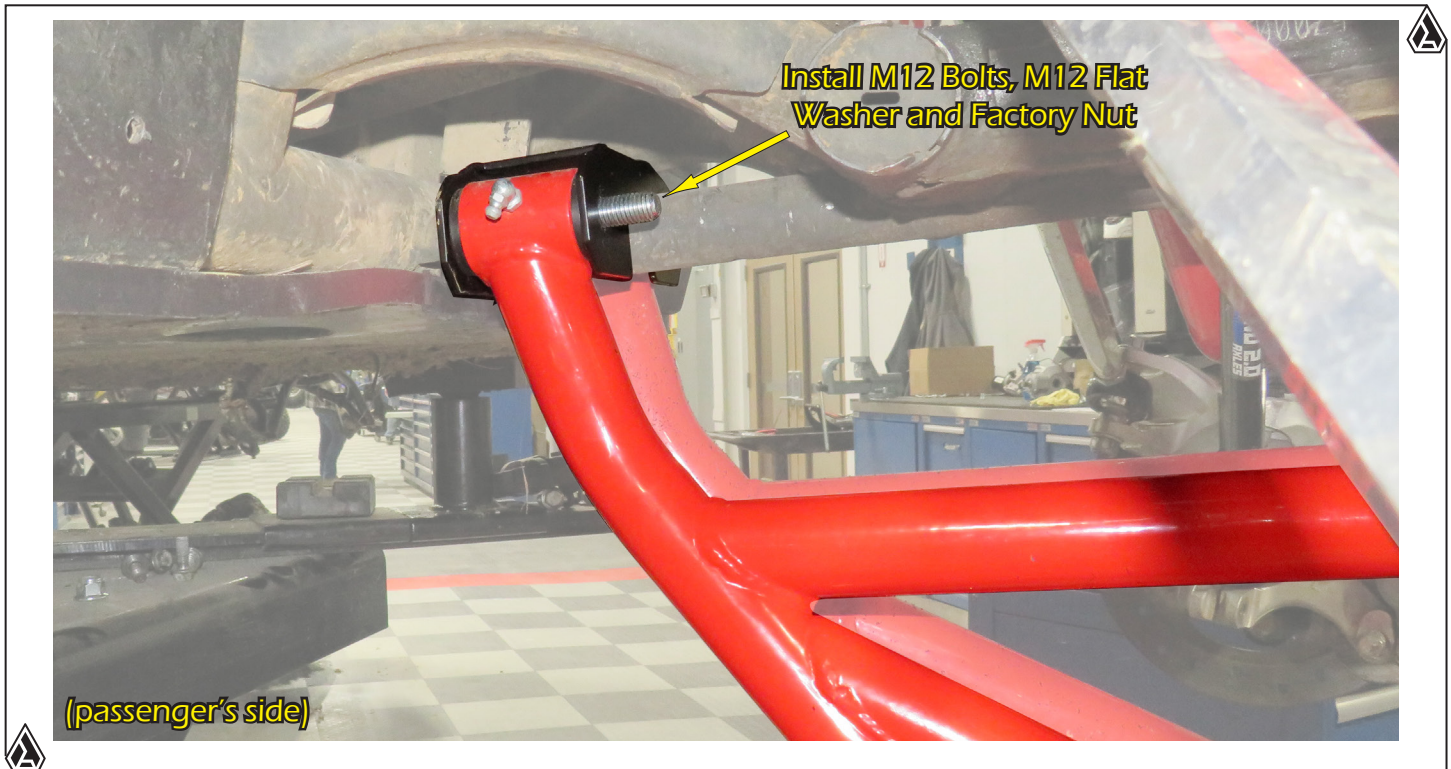

21. Secure Lower A-Arms to Shear Plate (F), Frame, and Lower Brace (D) with hardware shown. See Fig.21.

FIG.21

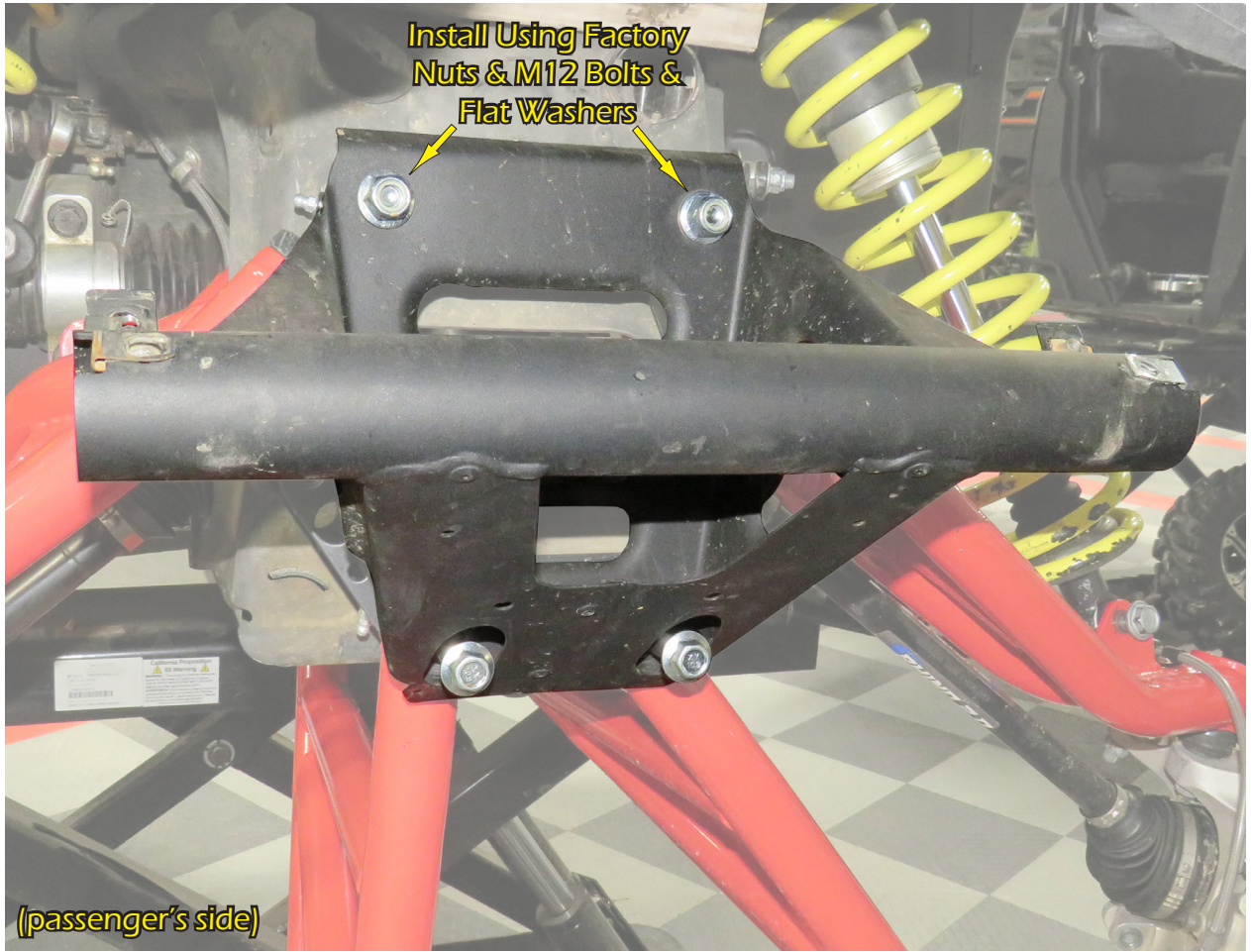

FIG.22

22. Reinstall stock **Bulkhead** with hardware shown. Secure **Lower A-Arms** to **Bulkhead**, **Frame**, **Mount (B)** and **Lower Plate (E)**. Tighten all hardware. - Reinstall all applicable stock components and tighten all hardware completely.



MAKE SURE THAT ALL BOLTS AND NUTS ARE TORQUED TO FACTORY SPECIFICATIONS AND ARE SECURE. PLEASE CONTACT ASSAULT INDUSTRIES FOR QUESTIONS REGARDING SPECIFICATIONS OR ANY OTHER QUESTIONS YOU MAY HAVE. THANKS!



#### Liability Statement

Assault Industries® products are designed to best fit user's ATV/UTV under stock conditions. Adding, modifying, or fabricating any factory or aftermarket parts will void any warranty provided by Assault Industries® and is not recommended. Assault Industries® products could interfere with other aftermarket accessories. If user has aftermarket products on machine, contact Assault Industries® to verify that they will work together.

Although Assault Industries® has thousands of satisfied customers, user should be aware that installing lift kits, long travel, or suspension kits, tires, etc. will change the ride of machine and may increase maintenance and part wear. Operating any off-road machine while, or after, consuming alcohol and/or drugs increases risk of bodily harm or death. No warranty or representation is made as to this product's ability to protect user from severe injury or death. Assault Industries® urges operators and occupants to wear a helmet and appropriate riding gear at all times.

By purchasing and installing Assault Industries® products, user agrees that should damages occur, Assault Industries® will not be held responsible for loss of time, use, labor fees, replacement parts, or freight charges. Assault Industries®, nor any 3rd party, will not be held responsible for any direct, indirect, incidental, special, or consequential damages that result from any product purchased from Assault Industries®. The total liability of seller to user for all damages, losses, and causes of action, if any, shall not exceed the total purchase price paid for the product that gave rise to the claim.

Assault Industries® will warranty only parts provided by Assault Industries®. Any damage or problems with OEM housings, bearings, seals, or other manufacturers' products will not be covered by Assault Industries®. Assault Industries® parts and products are not warranted if item was not installed properly, misused, or modified.

Installing, adding, modifying, or fabricating any factory or aftermarket product to your ATV/UTV may violate certain local, state, and federal laws. Be advised that laws vary depending on town, city, county, state, etc. Use of certain products on public streets, roads, or highways may be in violation law. The Buyer is solely and exclusively legally and personally responsible for any violation of the law by the installation or use of the product. You must abide by all local, state, and federal laws, including but not limited to vehicle safety, traffic laws, and ordinances. It is your responsibility to know the laws and how they apply to you.

The Buyer is responsible to fully understand the capability and limitations of his/her vehicle according to manufacturer specifications, warnings and instructions and agrees to hold Assault Industries® harmless from any damage resulting from failure to adhere to such specifications, warnings and/ or instructions. The Buyer is also responsible to obey all applicable federal, state, and local laws and ordinances when operating his/her vehicle while using this product, and the Buyer agrees to hold Assault Industries® harmless from any violation thereof.

#### LEAVE US FEEDBACK

Visit [Assaultind.com](http://Assaultind.com) and leave a review of your product purchase.

We appreciate your opinion.....  
.....even if you're wrong! 😊

#### NEED ADDITIONAL HELP?

Check out our YouTube channel  
Call us : (714) 799-6711  
Monday - Friday: 8am-5pm  
Email: [sales@assaultind.com](mailto:sales@assaultind.com)