

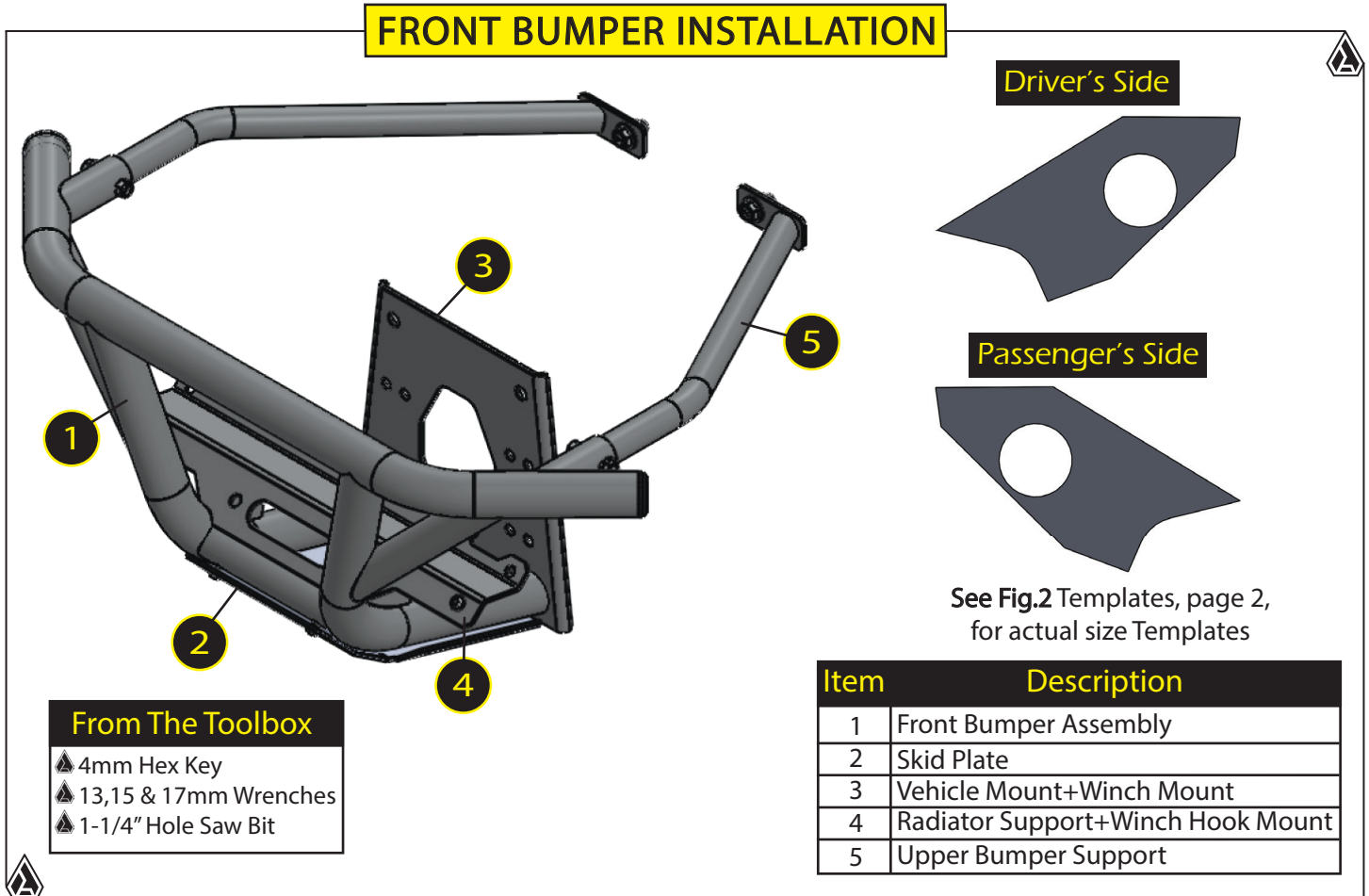

- ▲ Make sure the model on the instruction sheet matches your vehicle.
- ▲ Be sure to read all instructions and illustrations before starting.
- ▲ Do not discard packaging until product has been successfully installed.

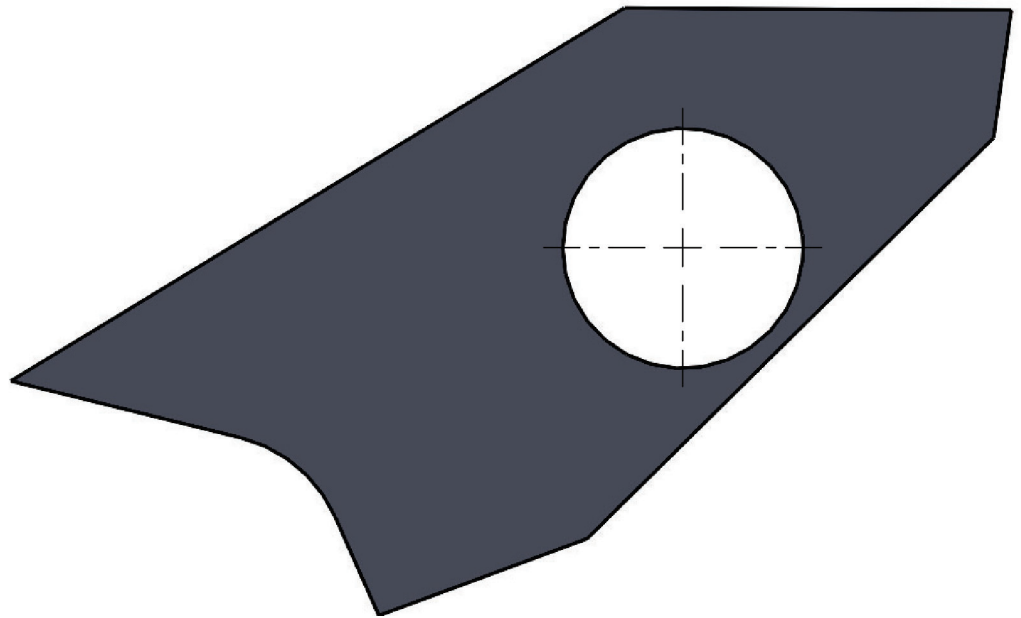

Fig.1

1. Raise the front of the vehicle.
2. Remove the 4 bolts from the chassis, remove bolts from the lower radiator support and remove the OEM front support.
3. Hold the bumper up to the front of the vehicle to get a rough idea of where the holes will need to be made in the plastics for the upper supports.
4. Apply masking tape over the area where the holes will be cut in the front plastics. Applying tape makes for a much cleaner cut through the plastics.
5. **Cut Out the Supplied Templates (Fig. 2)** with scissors and tape them to the areas under the headlights where the holes will be drilled. Hold the bumper up to the front of the vehicle again to recheck alignment of the templates. Use a hole saw to trim out the **1.25" Holes**.
6. Place the bumper against the frame with the plastics and radiator sitting atop the radiator support. When installing the bumper, place the upper bumper supports into their slots and add the **13mm Nut and Bolt**. Using the hardware removed in **Step 2**, secure the lower vehicle mount (**Items 1-3**).

7. Install the **Upper Bumper Supports (Items 1-5)** through the holes - install the **15mm Bolt** and add the **17mm Nut** to the back side.
8. Use the supplied **Hex Head Screw, Nut and Washer** to secure the radiator (**Items 1-4**) on the support.
9. Tighten all nuts and bolts.
10. Install the **Skid Plate (Items 1-2)** using 4 remaining **Hex Head Screws**.

NOTE: Cut and use THIS template for correct scale. If you decide to make a copy of this page, BE SURE you copy at 100% with no "Fit" or "Scaling" as this will change the size and hole spacing!

Driver's Side



Passenger's Side

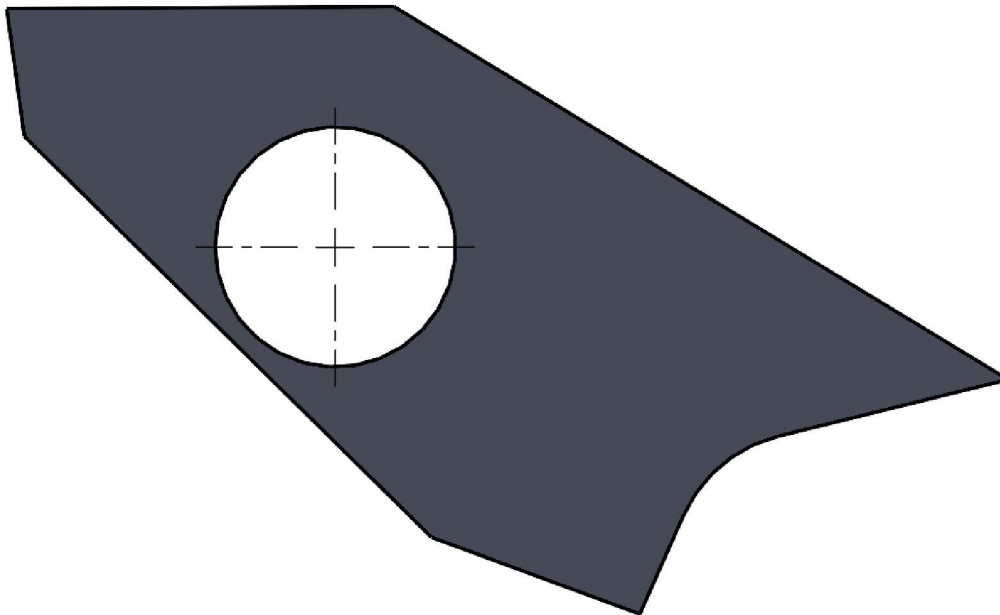
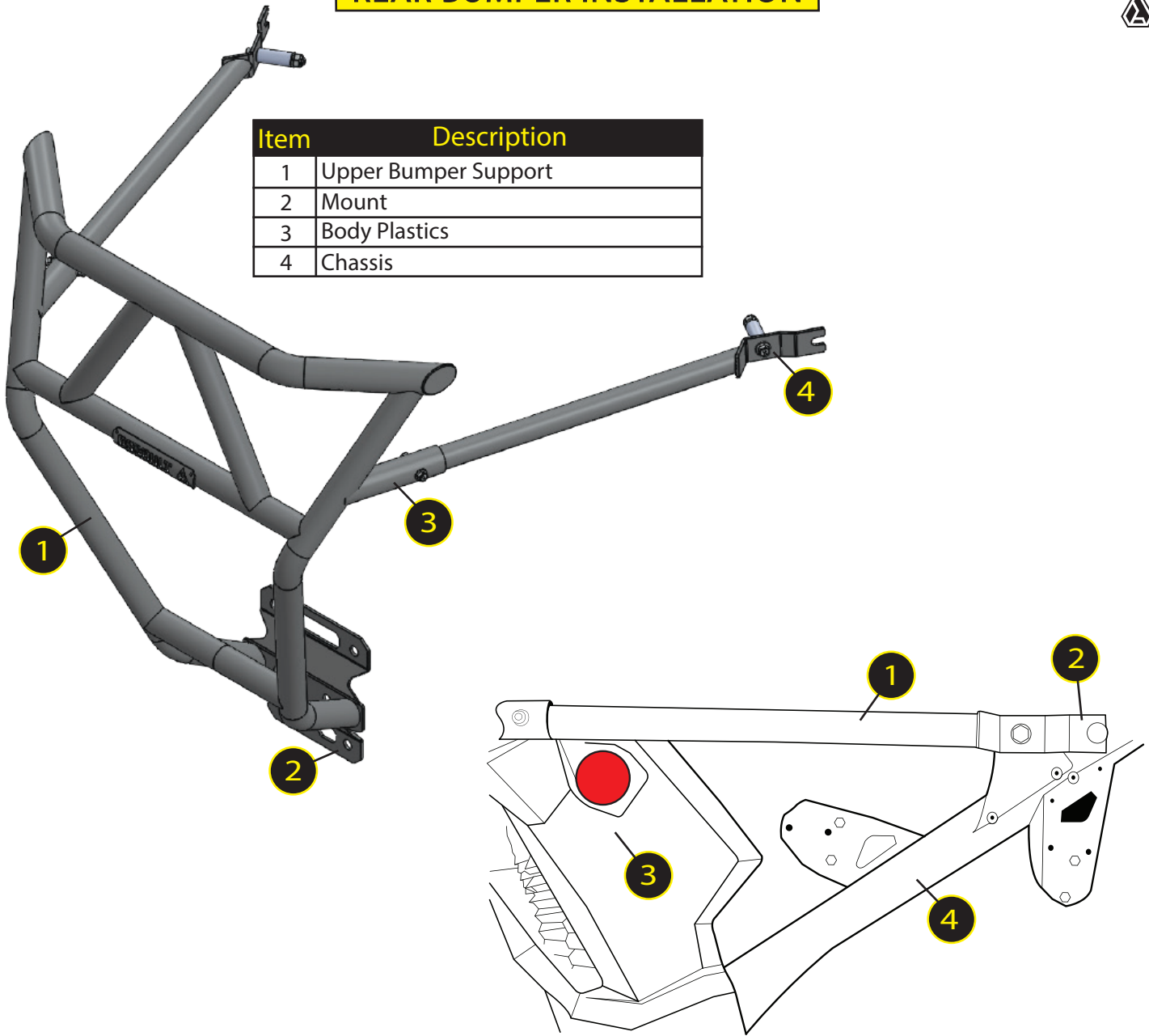

Fig.2

REAR BUMPER INSTALLATION

Item	Description
1	Upper Bumper Support
2	Mount
3	Body Plastics
4	Chassis



From The Toolbox
 ▲ 12,13,14 & 17mm Wrenches
 ▲ Thread Locker (optional)

Item	Description
1	Upper Bumper Support
2	Mount Point
3	Body Plastics
4	Chassis

Fig.1

1. Remove the 6 Nuts from the OEM radius rod chassis plate.
2. Using 14, 17mm Wrenches, install the Upper Bumper Support Arms (Items 1-3) on the chassis. The mount holes are already present so no drilling is required (Items 2-2). The slot at the end of the support arm will slide onto the round tab (Items 2-2). This step requires that you use the long bolt (14mm), Large Washer, Aluminum Spacer and M17 Nylock Nut.

3. Attach the **Bumper (Items 1-1)** to the chassis and insert the upper support arms into their holes. Secure with bolts.
4. Install the 6 nuts on the lower chassis mount.
5. Some alignment will be needed to center the bumper perfectly in the bed space.
6. Tighten all connections.



MAKE SURE THAT ALL BOLTS AND NUTS ARE TORQUED TO FACTORY SPECIFICATIONS AND ARE SECURE. PLEASE CONTACT ASSAULT INDUSTRIES FOR QUESTIONS REGARDING SPECIFICATIONS OR ANY OTHER QUESTIONS YOU MAY HAVE. THANKS!

Liability Statement

Assault Industries® products are designed to best fit user's ATV/UTV under stock conditions. Adding, modifying, or fabricating any factory or aftermarket parts will void any warranty provided by Assault Industries® and is not recommended. Assault Industries® products could interfere with other aftermarket accessories. If user has aftermarket products on machine, contact Assault Industries® to verify that they will work together.

Although Assault Industries® has thousands of satisfied customers, user should be aware that installing lift kits, long travel, or suspension kits, tires, etc. will change the ride of machine and may increase maintenance and part wear. Operating any off-road machine while, or after, consuming alcohol and/or drugs increases risk of bodily harm or death. No warranty or representation is made as to this product's ability to protect user from severe injury or death. Assault Industries® urges operators and occupants to wear a helmet and appropriate riding gear at all times.

By purchasing and installing Assault Industries® products, user agrees that should damages occur, Assault Industries® will not be held responsible for loss of time, use, labor fees, replacement parts, or freight charges. Assault Industries®, nor any 3rd party, will not be held responsible for any direct, indirect, incidental, special, or consequential damages that result from any product purchased from Assault Industries®. The total liability of seller to user for all damages, losses, and causes of action, if any, shall not exceed the total purchase price paid for the product that gave rise to the claim.

Assault Industries® will warranty only parts provided by Assault Industries®. Any damage or problems with OEM housings, bearings, seals, or other manufacturers' products will not be covered by Assault Industries®. Assault Industries® parts and products are not warranted if item was not installed properly, misused, or modified.

Installing, adding, modifying, or fabricating any factory or aftermarket product to your ATV/UTV may violate certain local, state, and federal laws. Be advised that laws vary depending on town, city, county, state, etc. Use of certain products on public streets, roads, or highways may be in violation law. The Buyer is solely and exclusively legally and personally responsible for any violation of the law by the installation or use of the product. You must abide by all local, state, and federal laws, including but not limited to vehicle safety, traffic laws, and ordinances. It is your responsibility to know the laws and how they apply to you.

The Buyer is responsible to fully understand the capability and limitations of his/her vehicle according to manufacturer specifications, warnings and instructions and agrees to hold Assault Industries® harmless from any damage resulting from failure to adhere to such specifications, warnings and/ or instructions. The Buyer is also responsible to obey all applicable federal, state, and local laws and ordinances when operating his/her vehicle while using this product, and the Buyer agrees to hold Assault Industries® harmless from any violation thereof.

Leave Us Feedback

Visit Assaultind.com and leave a review of your product purchase. We appreciate your opinion.....even if you're wrong! 😊

NEED ADDITIONAL HELP?

Check out our YouTube channel
Call us : (714) 799-6711
Monday - Friday: 8am-5pm
Email: sales@assaultind.com