



ASSAULT
INDUSTRIES



INSTALLATION INSTRUCTIONS

SW-U-BALLDL: BALLISTIC D-SHAPE LEATHER STEERING WHEEL

⚠ DO NOT DISCARD PACKAGING UNTIL PRODUCT HAS BEEN SUCCESSFULLY INSTALLED. ⚠ READ INSTRUCTIONS THOROUGHLY PRIOR TO INSTALLATION.



Steering Wheel



Back Plate



Face Plate



M5X16 BUTTON
HEAD (6PCS)
AND 3MM ALLEN
WRENCH (1PC)

FROM THE TOOLBOX

- ⚠ SOCKET SET
- ⚠ HEX KEY SETS
- ⚠ BLUE THREAD LOCKER (OPTIONAL)
- ⚠ VARIABLE TORQUE IMPACT



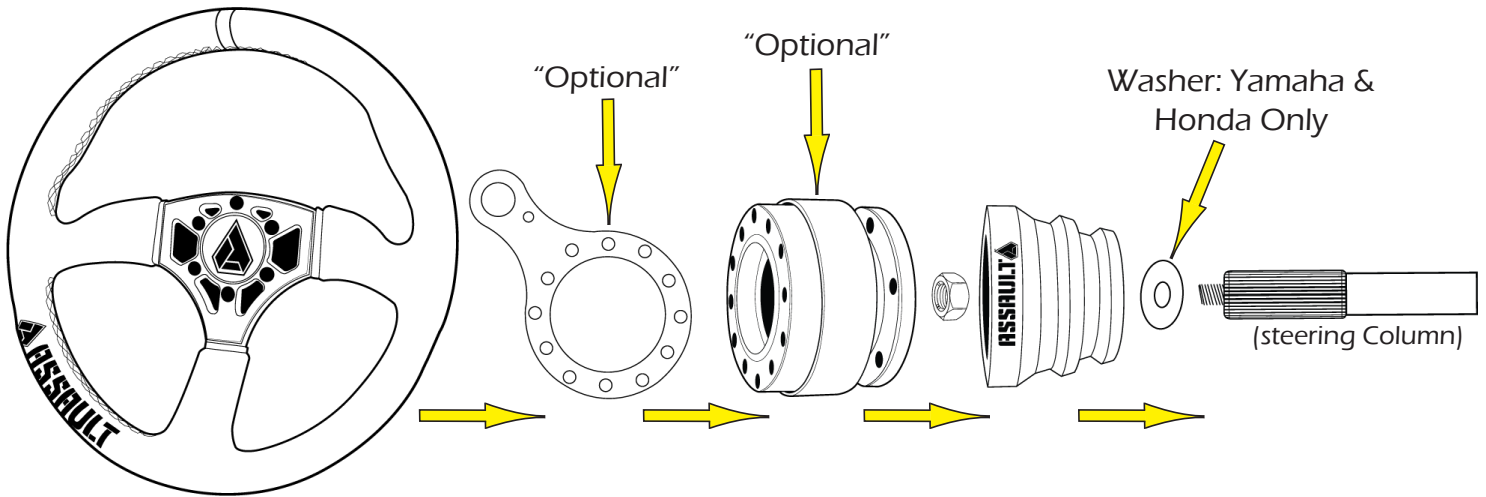

1. Make sure your wheels are at zero (completely straight) before removing the OEM steering wheel.
2. Unbolt and remove the OEM steering wheel. If it is difficult to remove, a steering wheel removal tool may be required to slide the wheel off of the taper.
3. Inspect the splines and threads on the column, clean dirt debris and thread locker before proceeding to the next step.
4. Install the hub logo side up with mount hole on "center". The logo should appear slightly offset.
5. Do not install the nut yet - add the steering wheel with a couple of bolts, get in the vehicle and drive it forward about 10-15 feet or enough to see if the wheel is tracking straight. If it is not exactly straight, **stop**, remove the wheel with hub attached and rotate it to the left or right on the spline and repeat this step until the wheel tracks correctly going in a straight line.
6. Once installed and tracking is satisfactory, park the vehicle, thread the nut onto the column, holding the wheel you can use an impact on a low setting or tighten with a ratchet. The nut should have an integrated nylon lock. Torque the nut to 30-35lbs. ft.
7. Remove the bolts holding the steering wheel in place and set it aside for optional accessories if applicable.

Quick Release: Holding the quick release mount with 2 hands, press the button and pull back the sleeve to release the male end from the main body. Using the supplied bolts install the male portion of the adapter to the hub. There is an indentation at the top of the base. That is the top. A dab of blue thread locker can be used to prevent bolts from loosening over time but it is not required. The main body will be installed directly to the back of the wheel.

Push To Talk Plate (PTT): The PTT plate installs between wheel and the quick release main body or if not using a quick release install between wheel and hub.

8. Place the optional accessories on a flat surface (if applicable) - first the main body of the quick release (The button should be at the top), then the PTT, aligning holes appropriately. Then place the wheel on top and orient the PTT where it will be most comfortable for your set up. Add the top plates for the

NOTE: Do Not Use Components Shown Below



MAKE SURE THAT ALL BOLTS AND NUTS ARE TORQUED TO FACTORY SPECIFICATIONS AND ARE SECURE. PLEASE CONTACT ASSUALT INDUSTRIES FOR QUESTIONS REGARDING SPECIFICATIONS OR ANY OTHER QUESTIONS YOU MAY HAVE. THANKS!

Liability Statement

Assault Industries® products are designed to best fit user's ATV/UTV under stock conditions. Adding, modifying, or fabricating any factory or aftermarket parts will void any warranty provided by Assault Industries® and is not recommended. Assault Industries® products could interfere with other aftermarket accessories. If user has aftermarket products on machine, contact Assault Industries® to verify that they will work together.

Although Assault Industries® has thousands of satisfied customers, user should be aware that installing lift kits, long travel, or suspension kits, tires, etc. will change the ride of machine and may increase maintenance and part wear. Operating any off-road machine while, or after, consuming alcohol and/or drugs increases risk of bodily harm or death. No warranty or representation is made as to this product's ability to protect user from severe injury or death. Assault Industries® urges operators and occupants to wear a helmet and appropriate riding gear at all times.

By purchasing and installing Assault Industries® products, user agrees that should damages occur, Assault Industries® will not be held responsible for loss of time, use, labor fees, replacement parts, or freight charges. Assault Industries®, nor any 3rd party, will not be held responsible for any direct, indirect, incidental, special, or consequential damages that result from any product purchased from Assault Industries®. The total liability of seller to user for all damages, losses, and causes of action, if any, shall not exceed the total purchase price paid for the product that gave rise to the claim.

Assault Industries® will warranty only parts provided by Assault Industries®. Any damage or problems with OEM housings, bearings, seals, or other manufacturers' products will not be covered by Assault Industries®. Assault Industries® parts and products are not warranted if item was not installed properly, misused, or modified.

Installing, adding, modifying, or fabricating any factory or aftermarket product to your ATV/UTV may violate certain local, state, and federal laws. Be advised that laws vary depending on town, city, county, state, etc. Use of certain products on public streets, roads, or highways may be in violation law. The Buyer is solely and exclusively legally and personally responsible for any violation of the law by the installation or use of the product. You must abide by all local, state, and federal laws, including but not limited to vehicle safety, traffic laws, and ordinances. It is your responsibility to know the laws and how they apply to you.

The Buyer is responsible to fully understand the capability and limitations of his/her vehicle according to manufacturer specifications, warnings and instructions and agrees to hold Assault Industries® harmless from any damage resulting from failure to adhere to such specifications, warnings and/ or instructions. The Buyer is also responsible to obey all applicable federal, state, and local laws and ordinances when operating his/her vehicle while using this product, and the Buyer agrees to hold Assault Industries® harmless from any violation thereof.

LEAVE US FEEDBACK

Visit Assaultind.com and leave a review of your product purchase.
We appreciate your opinion.....
.....even if you're wrong! 😊

NEED ADDITIONAL HELP?

Check out our YouTube channel
Call us : (714) 799-6711
Monday - Friday: 8am-5pm
Email: sales@assaultind.com