

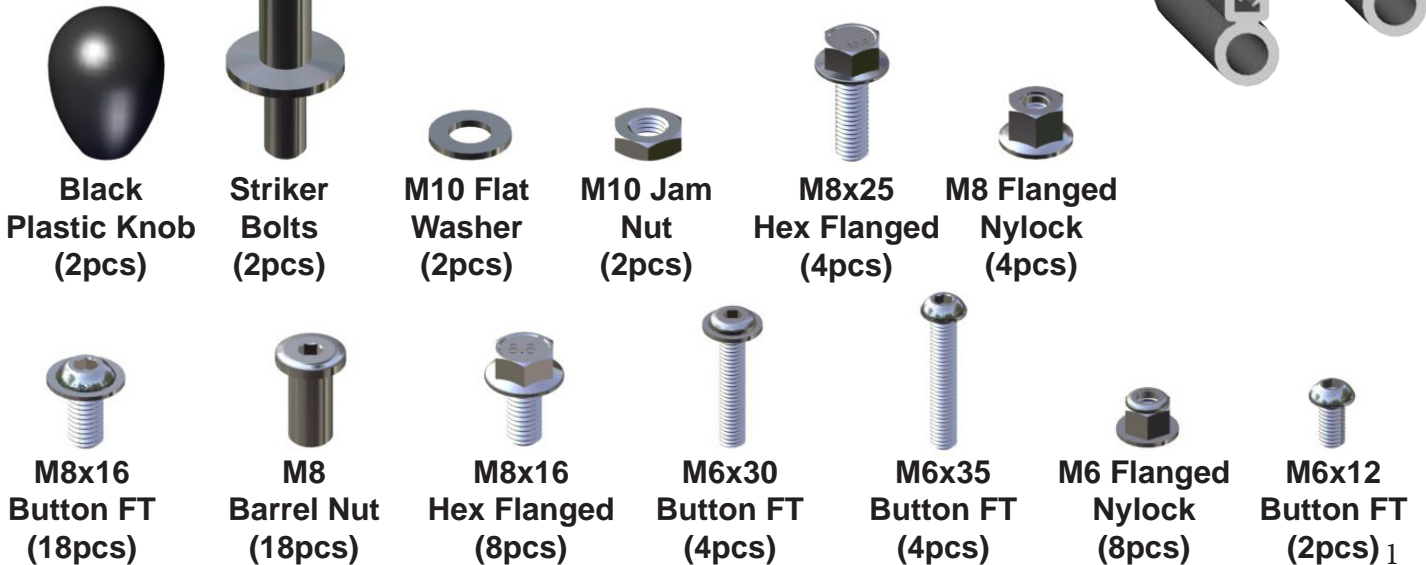

INSTALLATION INSTRUCTIONS

DOOR-P-RAN900-003: Half Door Kit

- 🔗 Please look through and read these instructions BEFORE starting so you understand what processes you'll be doing, and possible extra tools you may need.
- 🔗 Do Not discard product packaging until installation is complete and functioning properly.

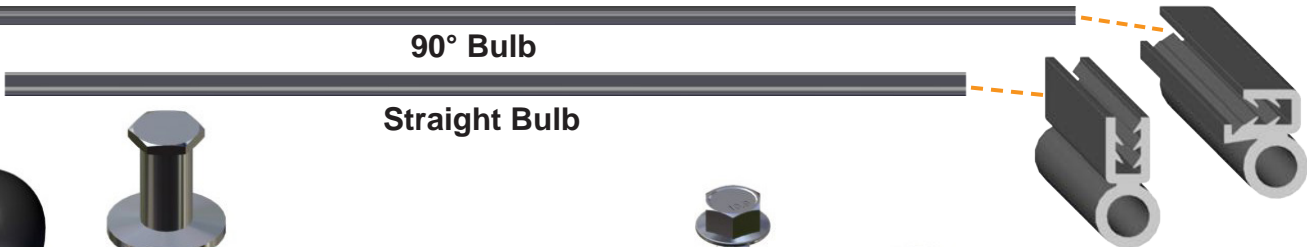
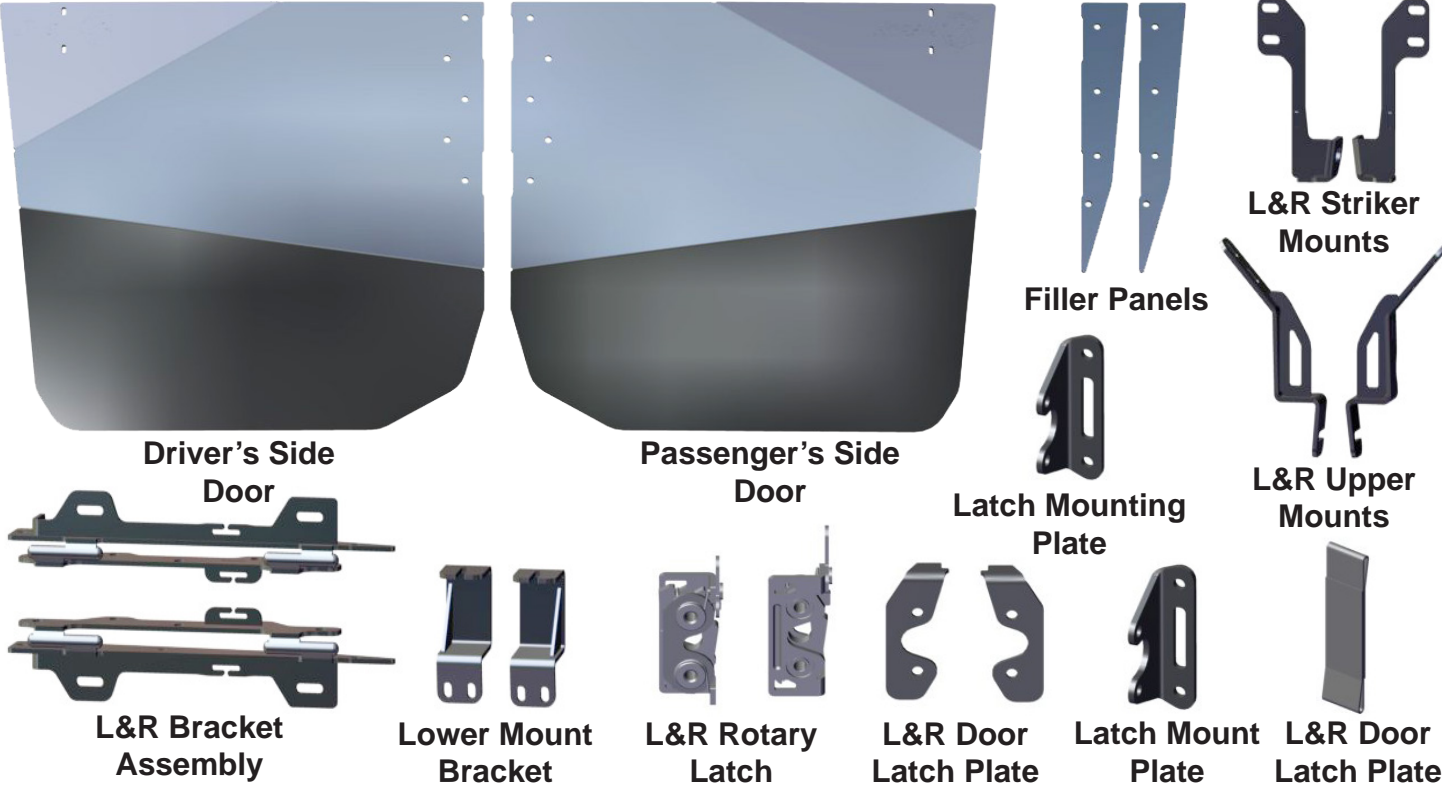

1. The first thing you need to do is **Remove any Netting Shoulder Bolsters or Foot Guards**, if any, on your machine so you can prep the machine for the install. See **Fig.1**.

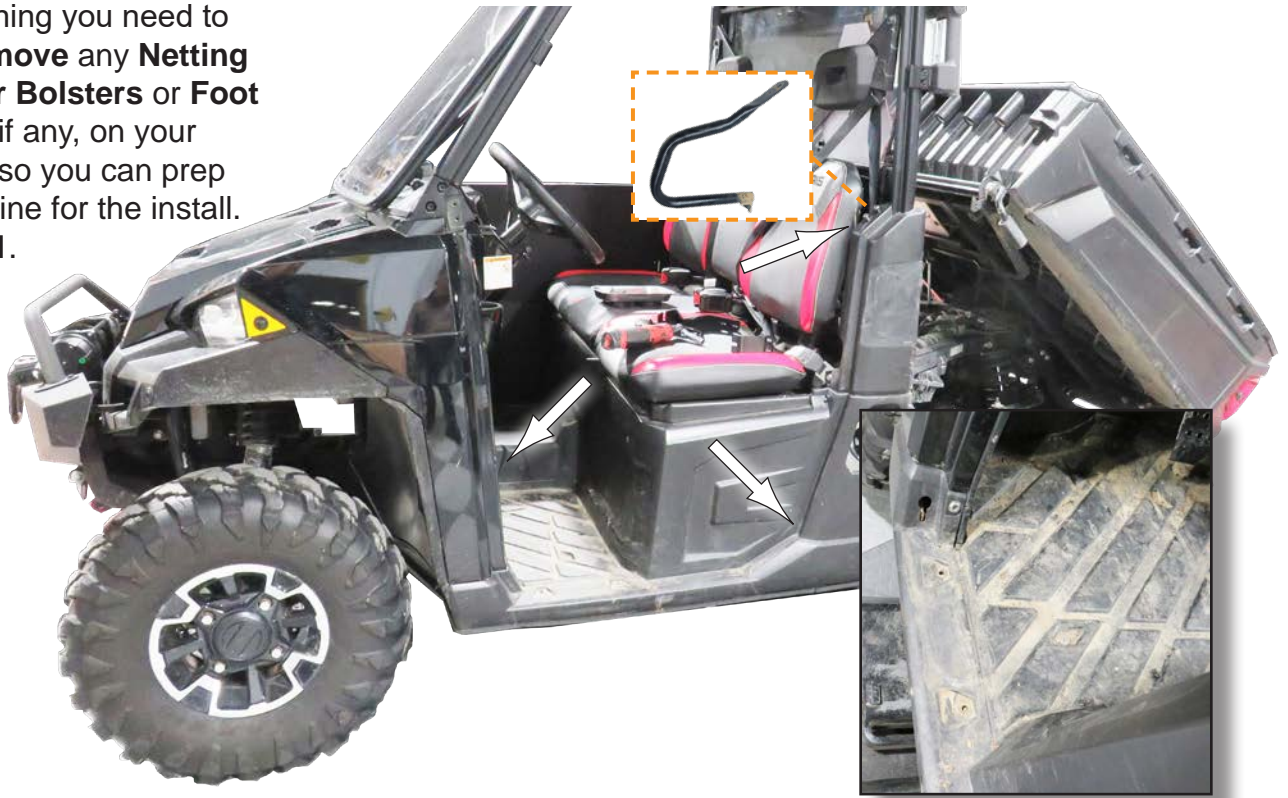

Fig.1

2. The next thing you will need to do is **Remove the Panel Screws, Push-Pins and a Band Clamp to Remove the Outer Side Panel by the door**. See **Fig.2a-c**.



Fig.2a



Fig.2b

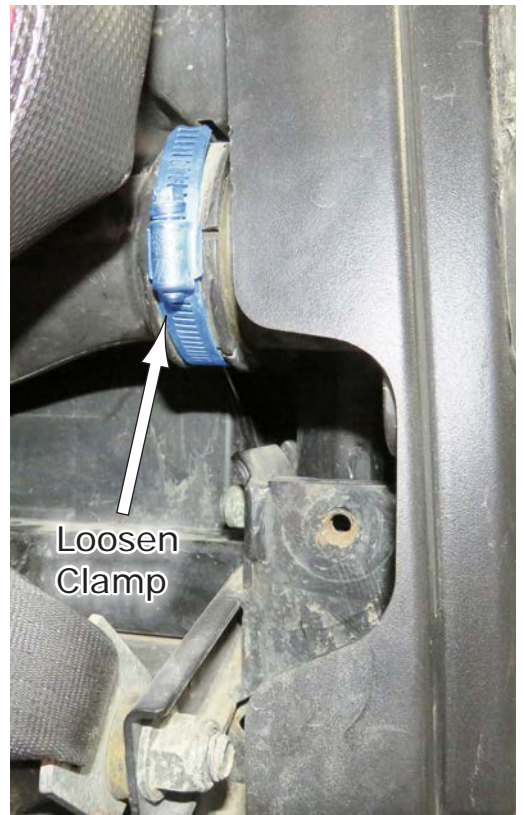

Fig.2c

3. Now Remove the Side Panel from the vehicle as shown in Fig.3a-b. Repeat for opposite side.



Fig.3a



Fig.3b

4. Next, find the **Lower Mount Bracket, Fig.4a**, and **Install** it onto the vehicle using the **M8x16Hex Flanged Bolts** provided in your kit as shown in **Fig.4b-c**.



Fig.4a



Fig.4b



Fig.4c

5. After the Lower Mount Bracket is installed, you can now **Replace** the **Outer Panel** previously removed ready to install the Upper Mount. See **Fig.5a**. Then find the **Upper Mount Bracket** for that side and Install it on the vehicle as shown in **Fig.5b** using the **Factory Screws** you previously removed, and tighten secure.



Fig.5a



Fig.5b

6. Now you need to **Pre-assemble** the **Door Hinges**. Simply do this by sliding the hinge pins from one half into the other half's hinge as shown in **Fig.6**.



Fig.6

Hinges Ready To
Install



7. Now find the **Filler Panel** for that side and **Install** the **90° Bulb Seal** to one edge as shown in **Fig.7a-b** if your panels do not have this already installed. You will need to “cut to fit” the bulb. Yours should look like the one in **Fig.7b**.



Fig.7a



90° Bulb Seal Installed

Fig.7b

8. After the bulb seal is on, you can now **Install** the **Hinge Assy** to the panel using the **(4) M8x16 Button Ft Screws** and **M8 Barrel Nuts** provided in your kit as shown in **Fig.8a-d**, tighten secure.

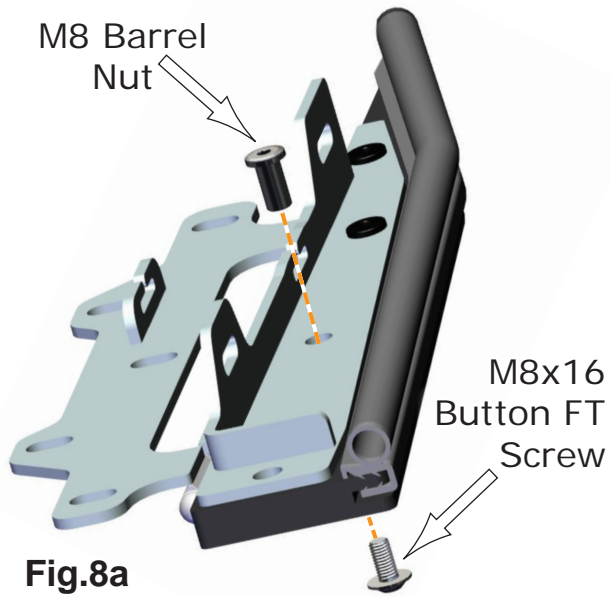

Fig.8a



Fig.8b

Hinge Assy Installed Onto Panel



Fig.8c



Fig.8c

9. Next **Pre-install** the two bolt locations using the **M8x25 Hex Flanged Bolts** and **M8 Flanged Nylock Nuts**, but **leave a little loose** so you can slide the hinge assy into the slotted bracket as shown in **Fig.a-e**. Then Slide Hinge Assy onto bracket slots and snug in place but do not

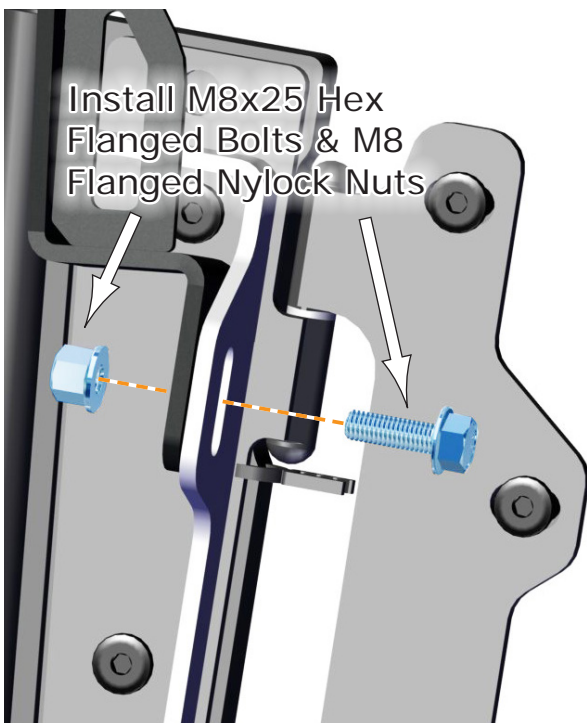

Fig.9a



Fig.9b



Fig.9c



Fig.9d

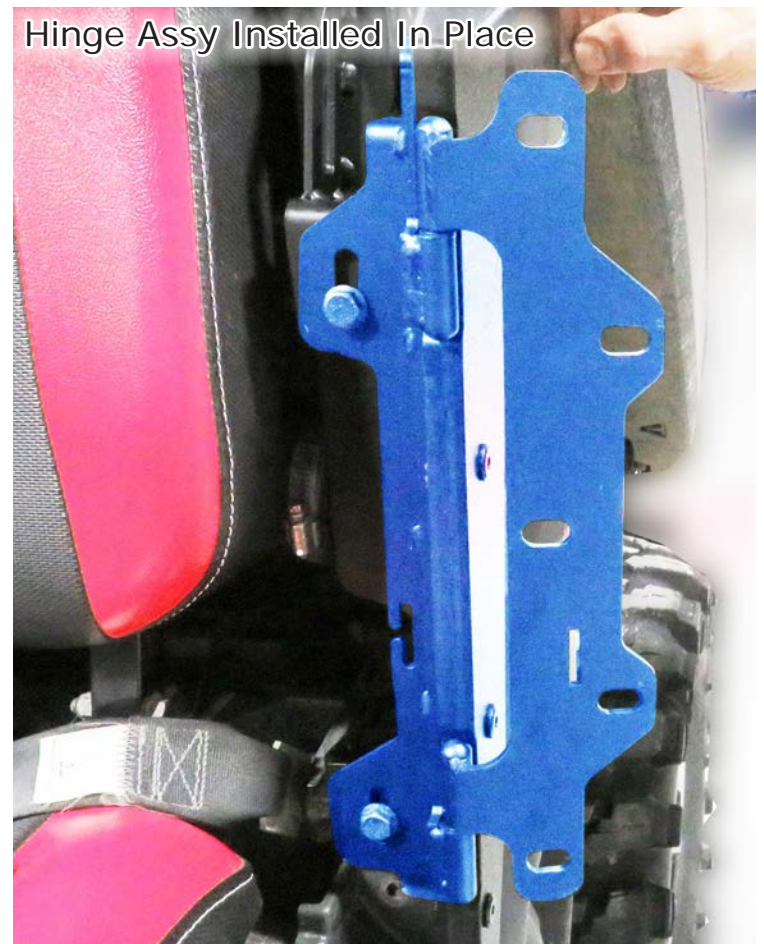

Fig.9e

10. Now you need to **Preassemble** the **Striker Mount** but installing the **Striker Bolt**, **M10 Jam Nut** and **M10 Flat Washer** onto the mount as shown in **Fig.10a-b**. Then Install it on to the machine using the **M8x16 Hex Flanged Bolts**. Center the bolts in the center of the slotted holes in the Striker Mount for the best place to start. You may need to adjust it later. See **Fig.10c-d**.



Fig.10a

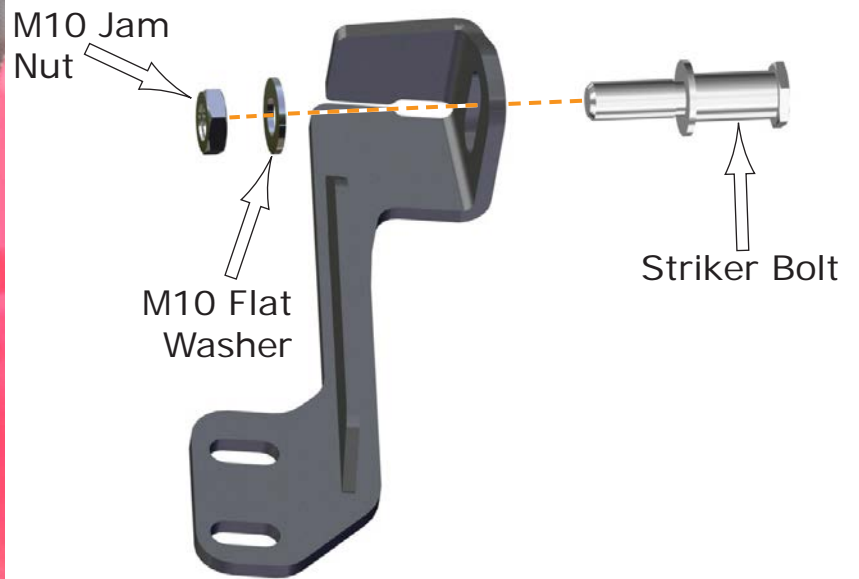

Fig.10b



Fig.10c



Fig.10d

11. Next you need to **Install the 90° Bulb Seal** Along the edges of the Door as shown in **Fig.11a-b**. You will need to “cut to fit” this item. Then you will need to **Install Two Pieces of Straight Bulb Seal** to fit along the straight side in the approximate locations. You can hold the door up to the Filler Panel you just installed after you install the 90° seal and see where these smaller straight bulbs should go, in between the hinges. See **Fig.11c-d**.

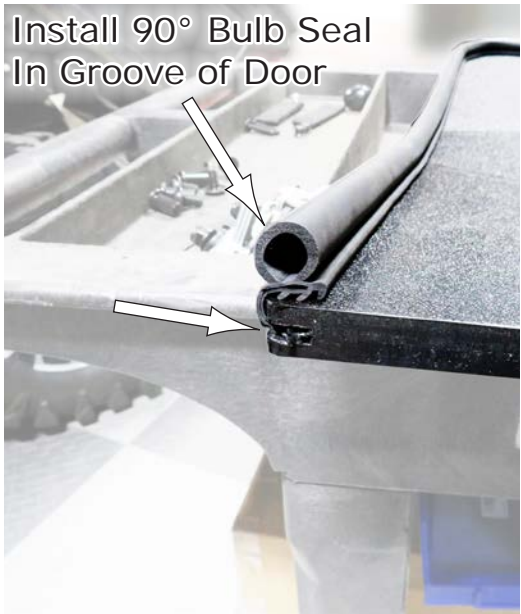

Fig.11a



Fig.11b



Fig.11c



Fig.11d

12. Now lift the door up to the Hinge Assy and **Install** it using the **M8x16 Button FT Screws & M8 Barrel Nuts** provided in your kit. We used a rod to help hold and align the holes while you install the barrel nuts. However a screw driver would work as well, if needed. See **Fig.12a-c**.



Fig.12a



Fig.12b



Fig.12c

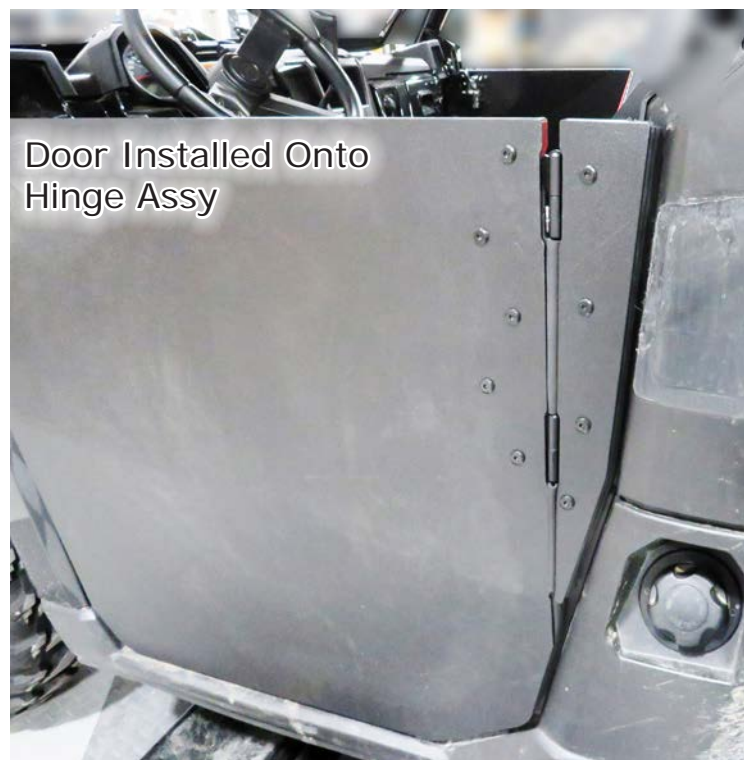

Fig.12d

13. Next, find the **Door Latch Parts** which you will need to assemble before installing it onto the door. **Fig.13** shows the parts you will need. The **Rotary Latch**, **Latch Mount Plate** and **Door Latch Plate** and Hardware etc. Assemble as shown.

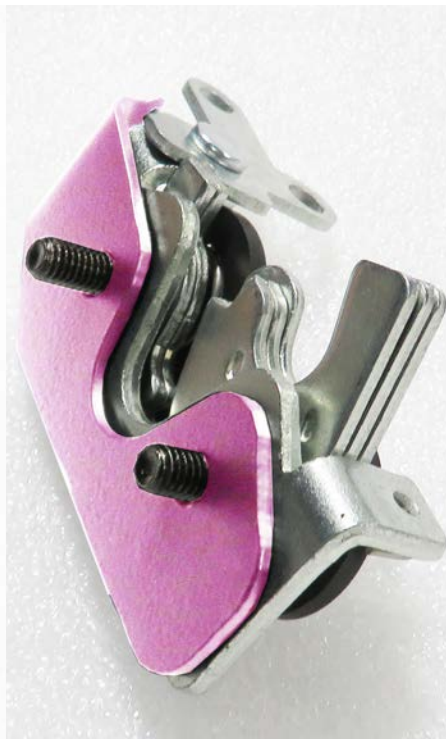
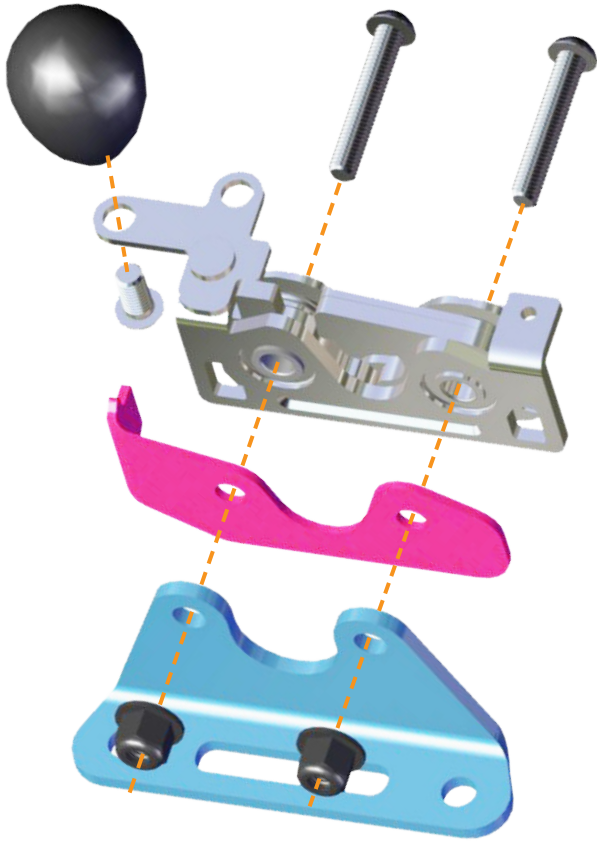

Fig.13

14. Now **Install** it onto the door using the **M6x30 Button Flanged Screws & M6 Nylock Nuts** provided in your kit. Once installed, try the latch and adjust any of the bolts and screws needed to the latch to catch securely then tighten all down secure. See **Fig.14a-d**.



Fig.14a



Fig.14b



Fig.14c



Fig.14d



Liability Statement

SuperATV's® products are designed to best fit user's ATV/UTV under stock conditions. Adding, modifying, or fabricating any factory or aftermarket parts will void any warranty provided by SuperATV® and is not recommended. SuperATV's® products could interfere with other aftermarket accessories. If user has aftermarket products on machine, contact SuperATV® to verify that they will work together.

Although SuperATV® has thousands of satisfied customers, user should be aware that installing lift kits, long travel, or suspension kits, tires, etc. will change the ride of machine and may increase maintenance and part wear. Operating any off-road machine while, or after, consuming alcohol and/or drugs increases risk of bodily harm or death. No warranty or representation is made as to this product's ability to protect user from severe injury or death. SuperATV® urges operators and occupants to wear a helmet and appropriate riding gear at all times.

By purchasing and installing SuperATV® products, user agrees that should damages occur, SuperATV® will not be held responsible for loss of time, use, labor fees, replacement parts, or freight charges. SuperATV®, nor any 3rd party, will not be held responsible for any direct, indirect, incidental, special, or consequential damages that result from any product purchased from SuperATV®. The total liability of seller to user for all damages, losses, and causes of action, if any, shall not exceed the total purchase price paid for the product that gave rise to the claim.

SuperATV® will warranty only parts provided by SuperATV®. Any damage or problems with OEM housings, bearings, seals, or other manufacturers' products will not be covered by SuperATV®. SuperATV® parts and products are not warranted if item was not installed properly, misused, or modified.

Installing, adding, modifying, or fabricating any factory or aftermarket product to your ATV/UTV may violate certain local, state, and federal laws. Be advised that laws vary depending on town, city, county, state, etc. Use of certain products on public streets, roads, or highways may be in violation law. The Buyer is solely and exclusively legally and personally responsible for any violation of the law by the installation or use of the product. You must abide by all local, state, and federal laws, including but not limited to vehicle safety, traffic laws, and ordinances. It is your responsibility to know the laws and how they apply to you.

The Buyer is responsible to fully understand the capability and limitations of his/her vehicle according to manufacturer specifications, warnings and instructions and agrees to hold SuperATV® harmless from any damage resulting from failure to adhere to such specifications, warnings and/ or instructions. The Buyer is also responsible to obey all applicable federal, state, and local laws and ordinances when operating his/her vehicle while using this product, and the Buyer agrees to hold SuperATV® harmless from any violation thereof.

If you have any problems/questions on this kit, contact us by email at [superatv.com](mailto:sales@superatv.com).

Need help with your installation?



sales@superatv.com



www.superatv.com



1-855-743-3427



8:00am - 9:00pm EST M-Th
8:00am - 7:00pm EST Friday
9:00am - 2:00pm EST Saturday

*Thank You
For Choosing*



Like SuperATV on Facebook to keep up to date on new products!