

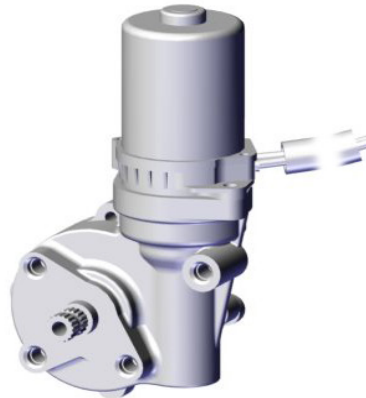
**INSTALLATION INSTRUCTIONS**  
**Power Steering Kit: PS-H-RAN420-380W**



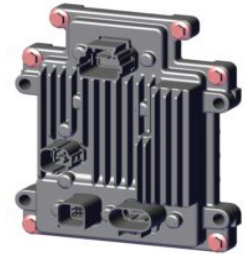
**Upper Steering Shaft Assembly**



**Motor Mounting Bracket**



**Power Steering Motor**



**10.7-80 ECU**









**Lower Steering Shaft Assembly**



**Universal Power Steering Wire Harness**



**3' 380W Wire Harness Extensions**

-   
**M10 Nylock Nut (1pc)**
-   
**M10 Flat Washer (1pc)**
-   
**M8x20 Hex Flanged (4pcs)**
-   
**M10x20 Hex Flanged (4pcs)**
-   
**M8x20 Hex Flanged (8pcs)**
-   
**Heat Shrink Tube (1pc)**



**M10x180 Hex Bolt (1pc)**



**Spade Terminal (3pcs)**



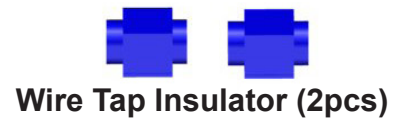
**Ring Connector (1pcs)**



**Barrel Connector (1pcs)**



**Power Harness (1pc)**



**Wire Tap Insulator (2pcs)**

1. The first thing you will need to do is remove the **Seat, Side Panels** on both sides and the **Hood** from the vehicle.



Fig.1a



Fig.1b

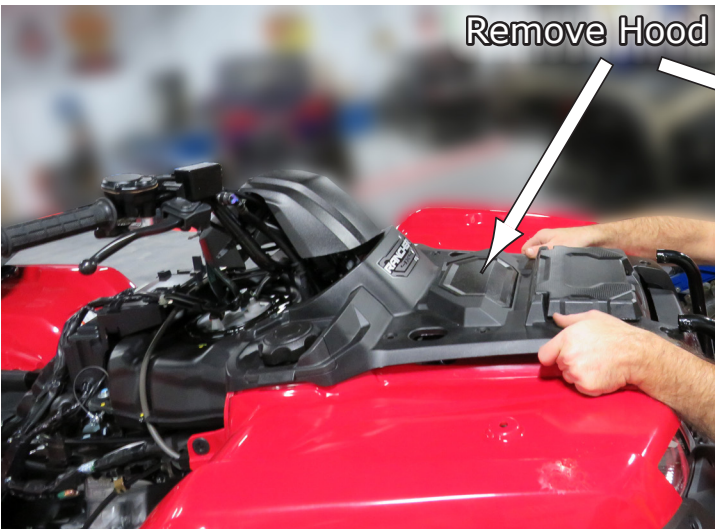


Fig.1c



Fig.1d

2. Next, you need to remove the shocks from both sides of the vehicle to gain clearance for the installation. See **Fig.2**.

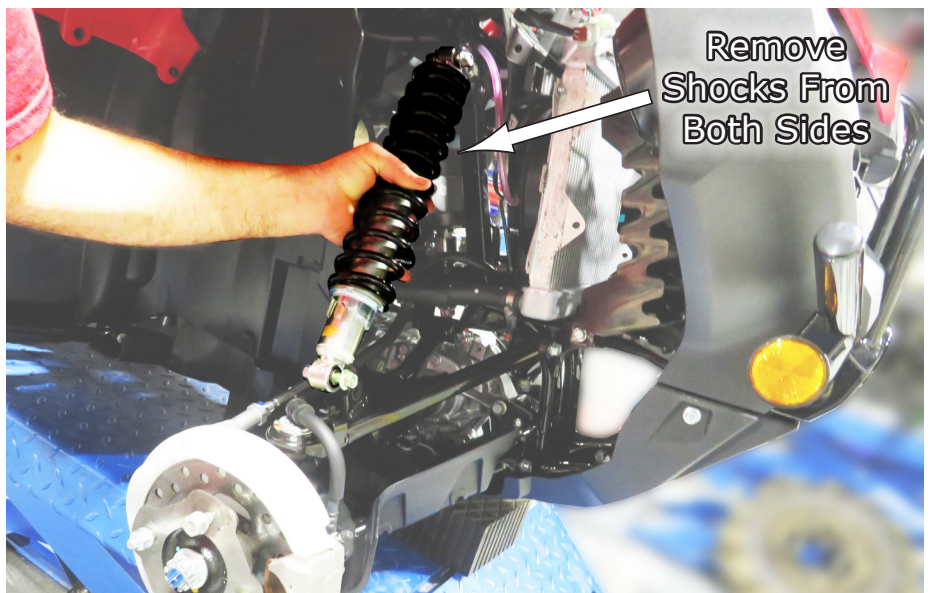
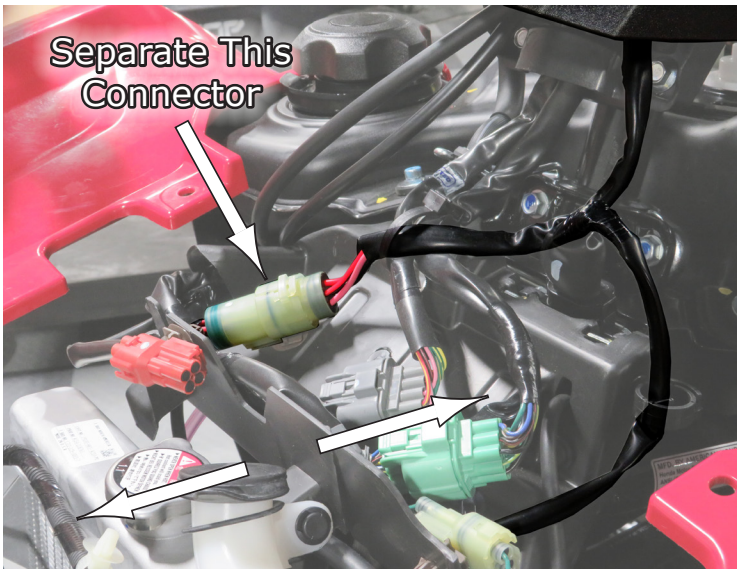


Fig.2



3. Now you will need to remove the shroud that surrounds the display. But first you need to disconnect the wires to do this. The shroud must come off as you will also be removing the handle bars in the coming steps. So first disconnect the main connector shown in **Fig.3a-b**.



**Fig.3a**



**Fig.3b**

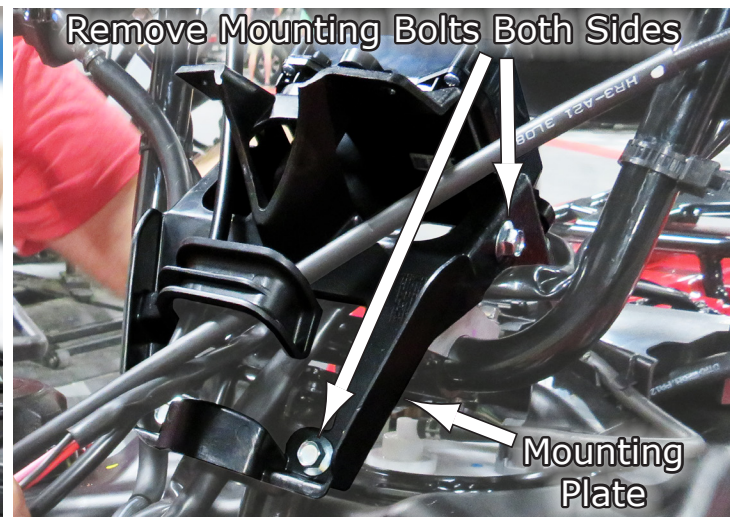


4. After the main connector is disconnected and any other connections holding the shroud in place, remove Shroud as shown in **Fig.4a**.

Then remove the **Mounting Bolts** holding the **Mounting Plate** on and remove the **Mounting Plate** as shown in **Fig.4b**.

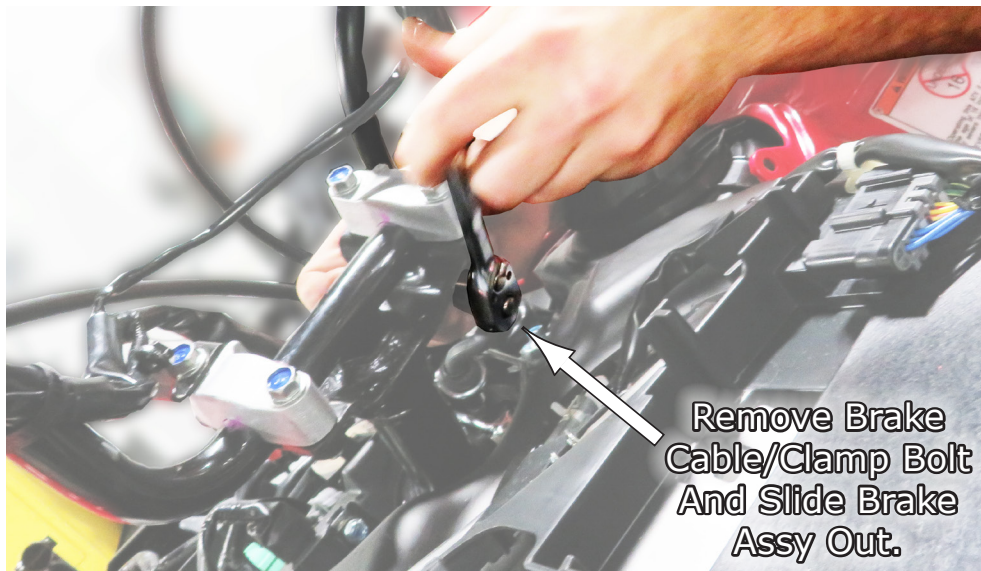


**Fig.4a**



**Fig.4b**

5. Now you need to disconnect the **Brake Line Cable** and clamp. Remove the bolt right under the handle bar clamps as shown in **Fig.5** then the cable and clamp slide out. See **Fig.5**.

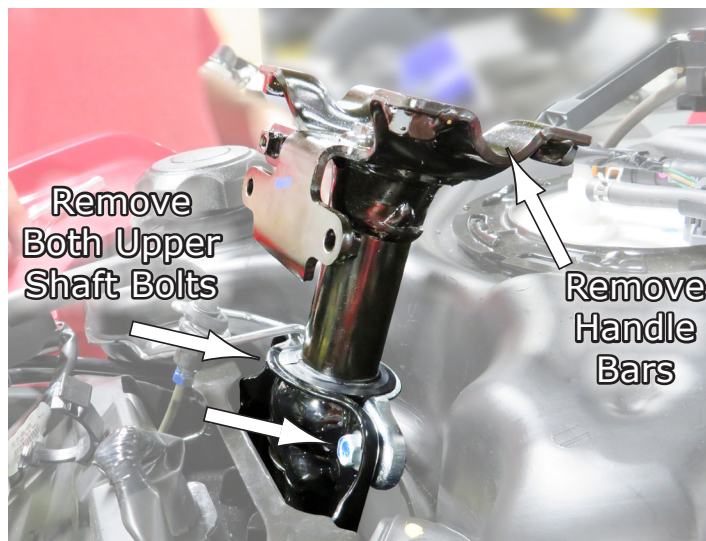


**Fig.5**

6. After the brake cable assembly is out of the way, now you can remove the **Handle Bars** by removing the two (2) **Bar Clamps**. Remove the bolts and remove the clamps. See **Fig.6a**. Then remove the **Handle Bars** and Two (2) upper shaft bolts as you will be removing the **Steering Shaft** in the coming steps. See **Fig.6b**. Save all bolts, clamps and parts removed as you will reuse them.

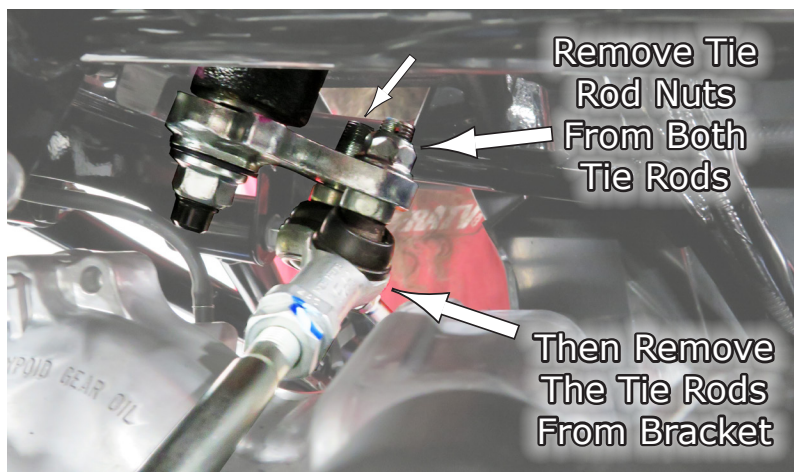


**Fig.6a**



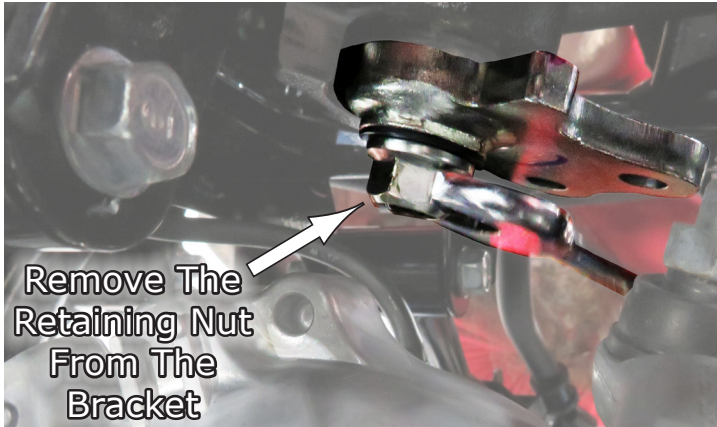
**Fig.6b**

7. You now need to disassemble the lower end of the shaft. First, remove the **Tie Rod Nuts** from the **Tie Rods** and remove the **Tie Rods** from the **Tie Rod Bracket** as shown in **Fig.7**.

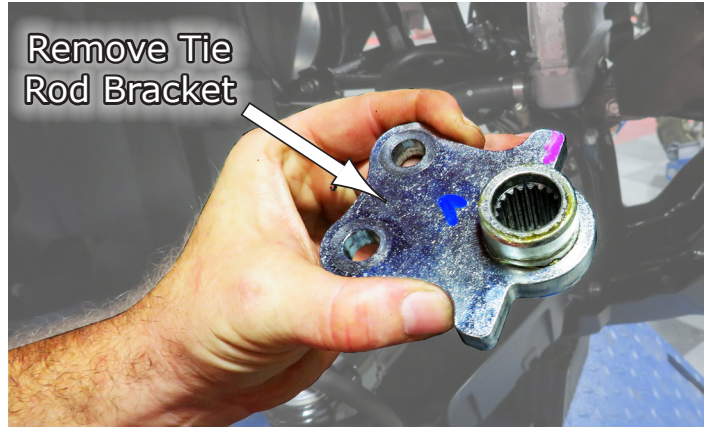


**Fig.7**

8. After the **Tie Rods** are removed, you can now remove the **Retaining Nut** for the **Tie Rod Bracket** as shown in **Fig.8a**. Then remove the **Tie Rod Bracket** from the machine as shown in **Fig.8b**.

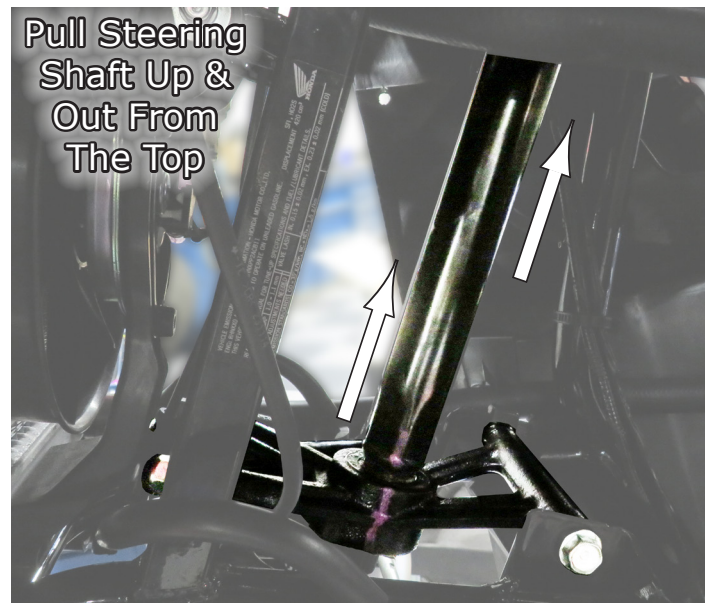


**Fig.8a**



**Fig.8b**

9. Now Pull Steering Shaft up and out of the machine from the top side of the vehicle. See **Fig.9a-b**.



**Fig.9**

10. After removing the Factory Shaft, Remove the **Rubber Grommet Seal** from the shaft as you will use it on your **New Steering Shaft**. See **Fig.10a-b**.

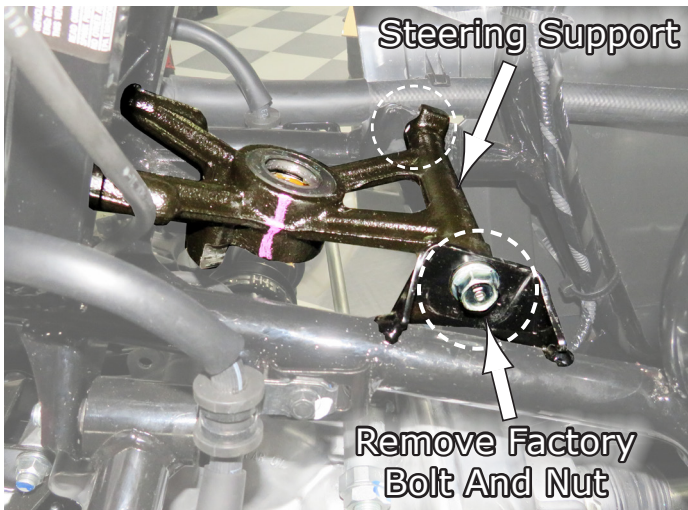


**Fig.10a**

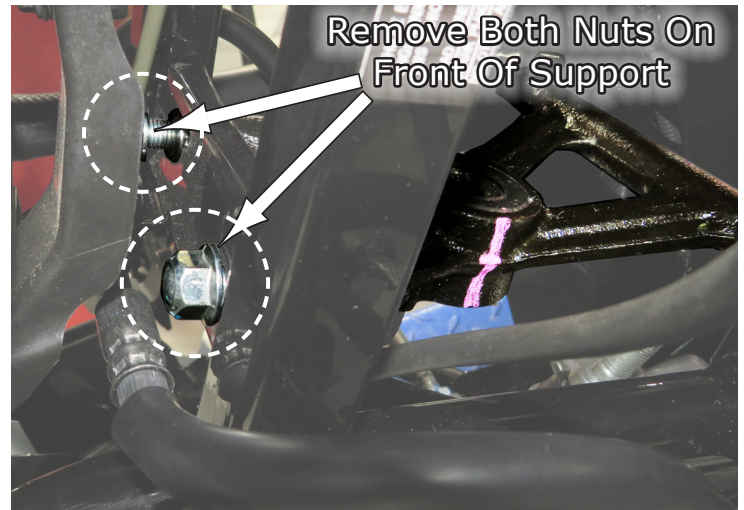


**Fig.10b**

11. Next you will need to remove the lower **Steering Shaft Support**. Do this by removing the rear Factory bolt and nut holding it to the frame as shown in **Fig.11a**. Then remove the two (2) large nuts on the front of the support as shown in **Fig.11b**.



**Fig.11a**



**Fig.11b**

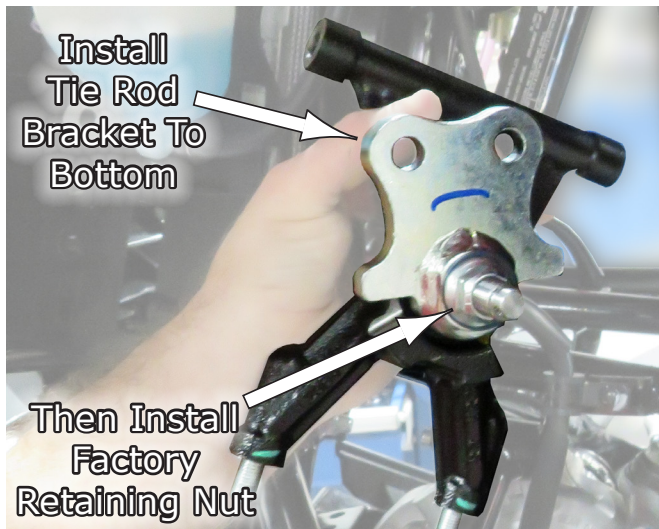
12. Now install the **Lower Steering Shaft Assembly** from your kit into the **Steering Support** as shown in **Fig.12a-b**. It installs from the top down, as in **Fig.12b**, the two bolt ends towards the front of the vehicle. Then install the Tie Rod Bracket onto the bottom and then the Factory retaining nut as shown in **Fig.12c**. Tighten securely.



**Fig.12a**



**Fig.12b**



**Fig.12c**



13. Now install the whole assembly back into the machine using the **Factory Nuts** on the front end and install the **Factory Long Bolt** to hold in place until you install the **Motor Mounting Bracket**. See **Fig.13a-b**. Leave bolt and nuts a little loose until **Motor Mounting Bracket** is installed.

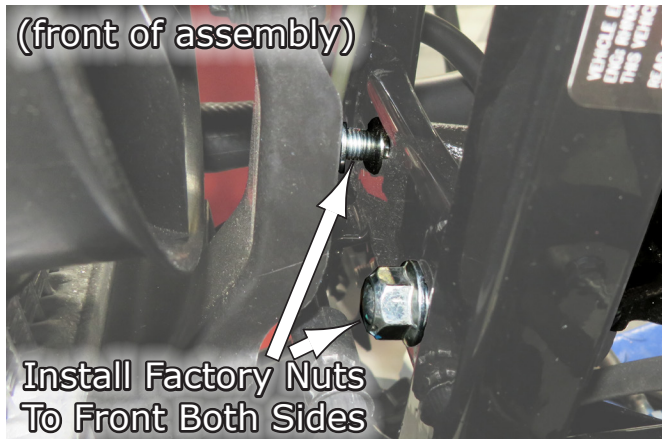


Fig.13a

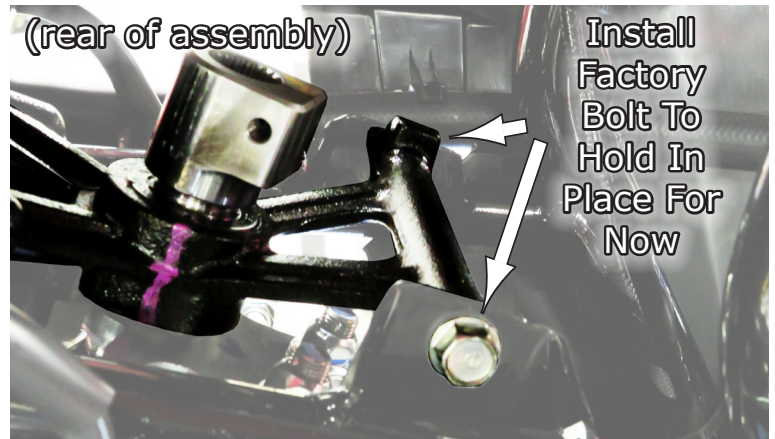


Fig.13b

14. Next you will install the **Motor Mounting Bracket**. This will go over the **Steering Support Assembly** you just installed. **Fig.14a-b** shows this bracket feeding in above the Steering Support.



Fig.14a

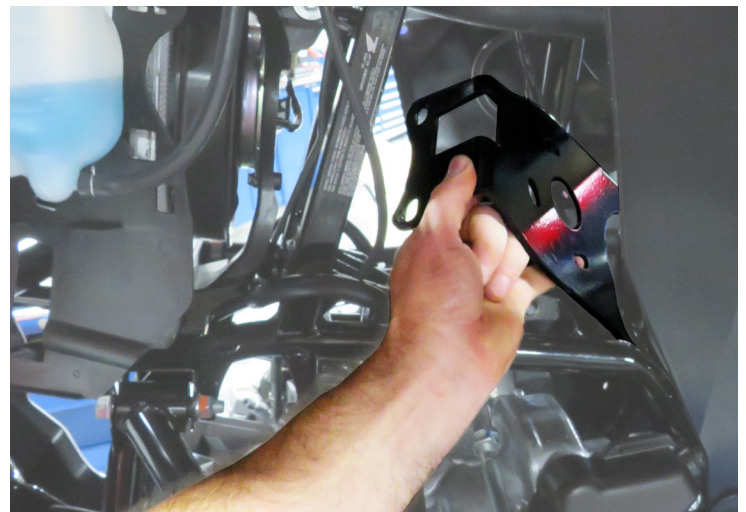
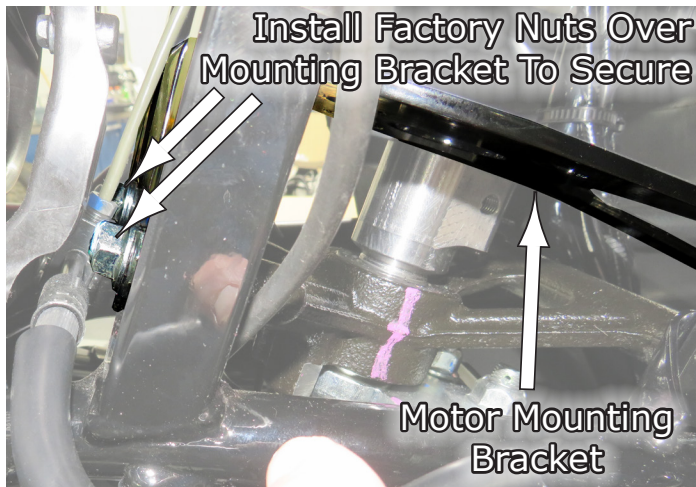


Fig.14b



15. Then take off the two (2) **Factory Nuts** from the front of the support and slip the front of the **Motor Mounting Bracket** over the front and allowing the threaded ends to go thru the holes in the bracket, and then replace the **Factory Nuts** as shown in **Fig.15a**. Then remove the **Factory Long Bolt** going thru the rear section of the **Steering Support** and slip the **Motor Mounting Bracket** ear tabs over the holes and install the **M10x180 Hex Bolt**, **M10 Flat Washer** and **M10 Nylock Nut** provided in your kit. Then tighten all bolts down securely. See **Fig.5b**.



**Fig.15a**

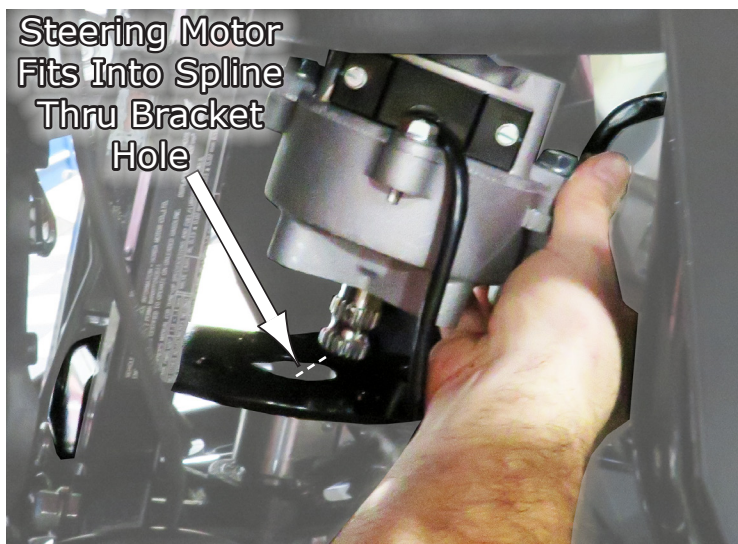


**Fig.15b**

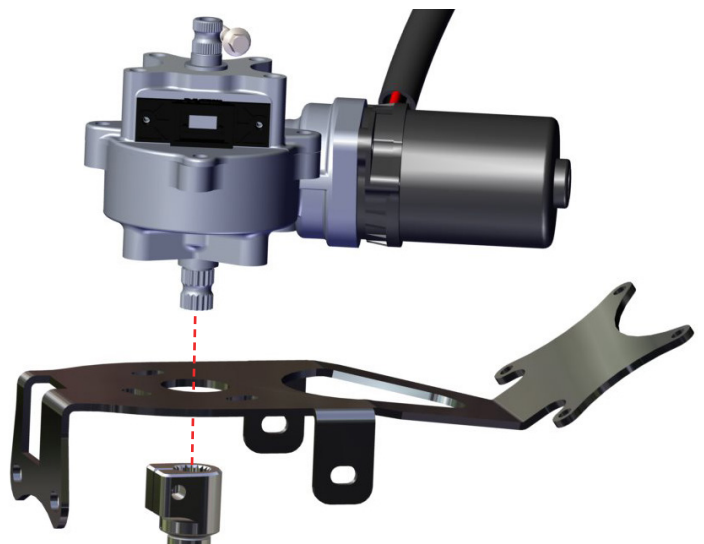
16. After you have tightened the **Motor Mounting Plate** down securely, now you can install the **Power Steering Motor** on top of the **Mounting Bracket**. **Fig.16a-c** shows how the motor spline goes thru the **Mounting Bracket** and into the **Lower Steering Shaft**. Once this is fitted in to the **Lower Steering Shaft**, you will now bolt it to the bracket and spline in the next steps. See **Fig.16a-c**.



**Fig.16a**

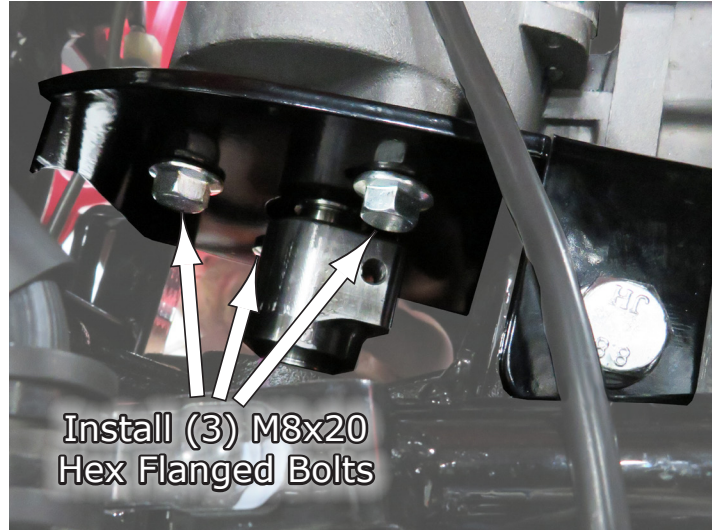
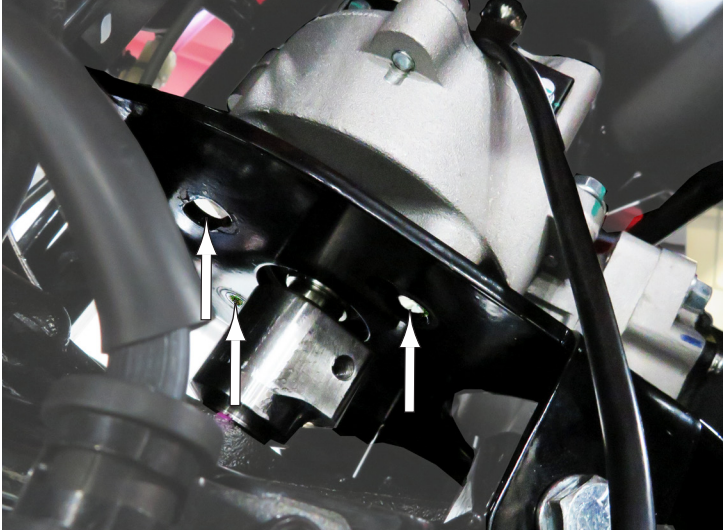


**Fig.16b**



**Fig.16c**

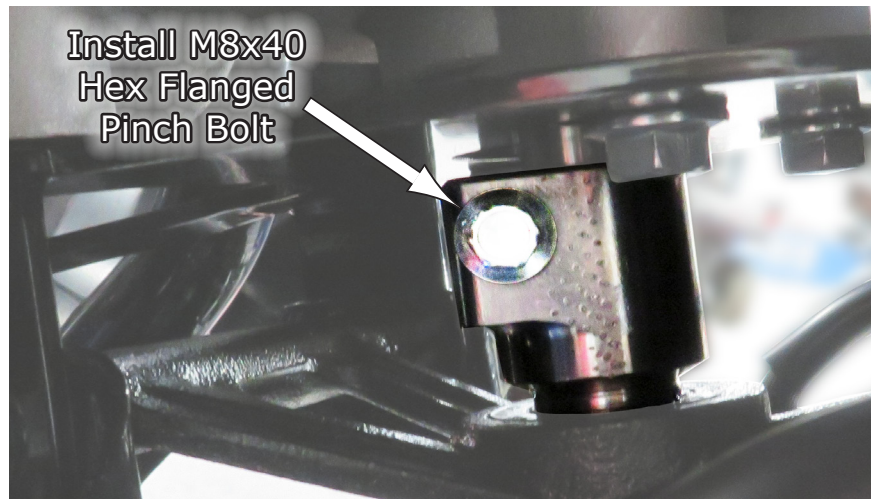
17. Now that the motor spline is in the **Lower Steering Shaft**, you can now bolt the motor to the **Mounting Bracket** by using the **M8x20 Hex Flanged Bolts** provided in your kit, and tighten securely. See **Fig.17a-b**.



**Fig.17a**

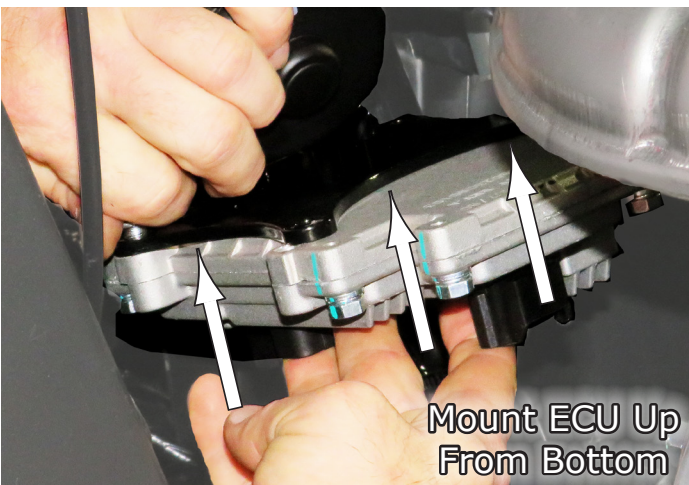
**Fig.17b**

18. After the motor is secured to the **Mounting Bracket**, now install the **M8x40 Hex Flanged** pinch bolt that goes in the **Lower Steering Shaft** as shown in **Fig.18**, also provided in your kit. Tighten secure.



**Fig.18**

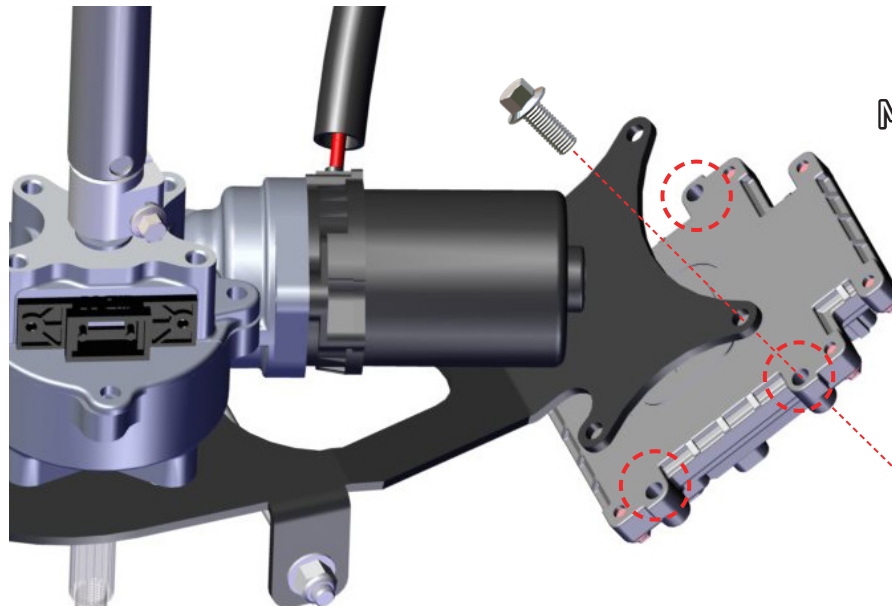
19. Now locate the **ECU** from your Kit. You will mount it from the under side of the **Motor Mounting Bracket** in the same orientation shown in **Fig.19a-b**. Install it using the **M8x20 Hex Head Bolts** provided in your kit. Bolts will thread into the **ECU** as shown in **Fig.19b-c**.



**Fig.19a**



**Fig.19b**



Install ECU To  
Mounting Bracket  
As Shown

Fig.19c

20. Now locate the **Rubber Grommet Seal** you took off the factory upper steering shaft previously and your **New Upper Steering Shaft**, and install the grommet as shown in **Fig.19a-b**.



Install Factory  
Rubber Grommet  
Onto New Shaft

Fig.20a



Split Grommet  
Fits Around Shaft

Fig.20b

21. And install the **Upper Shaft** down from the top, same location as you removed the factory shaft previously. See **Fig.21**.

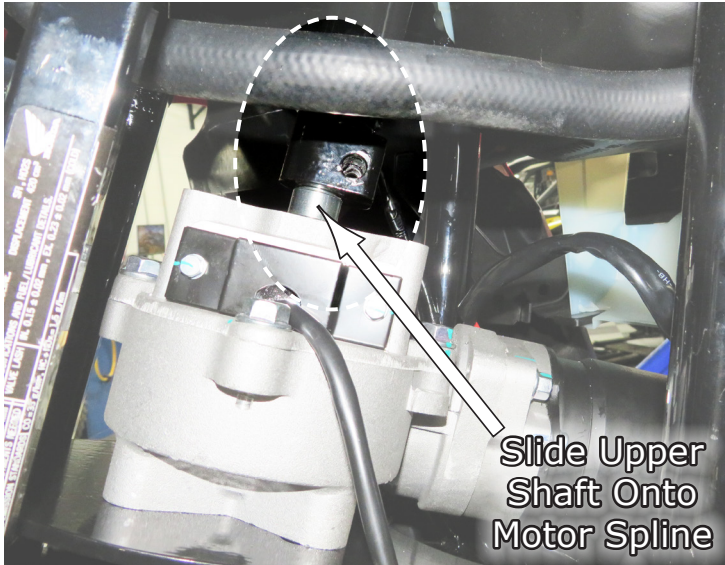


Install Upper  
Shaft Down To  
Motor Spline

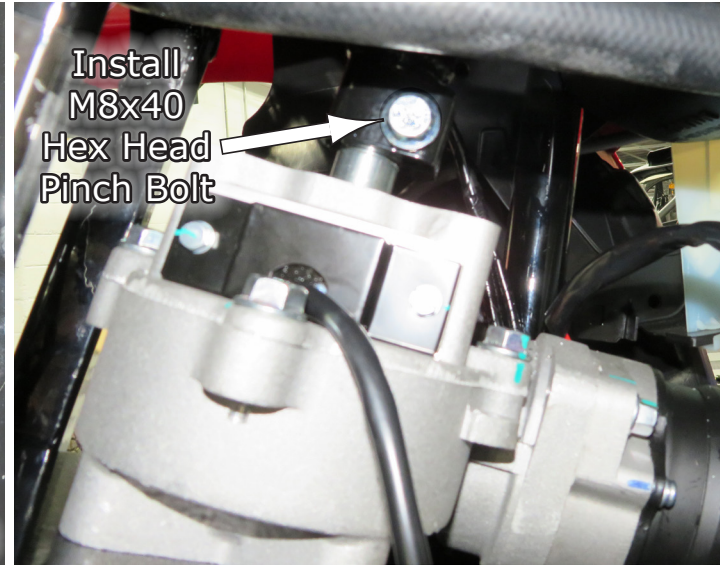
Fig.21



22. Slide the bottom of the shaft onto the spline of the steering motor as shown in **Fig.22a**. Then install the **M8x40 Hex Head Pinch Bolt** provided and tighten secure. **NOTE: Be sure you are aligned up top so the handle bars will be in the correct position before tightening pinch bolt.**



**Fig.22a**

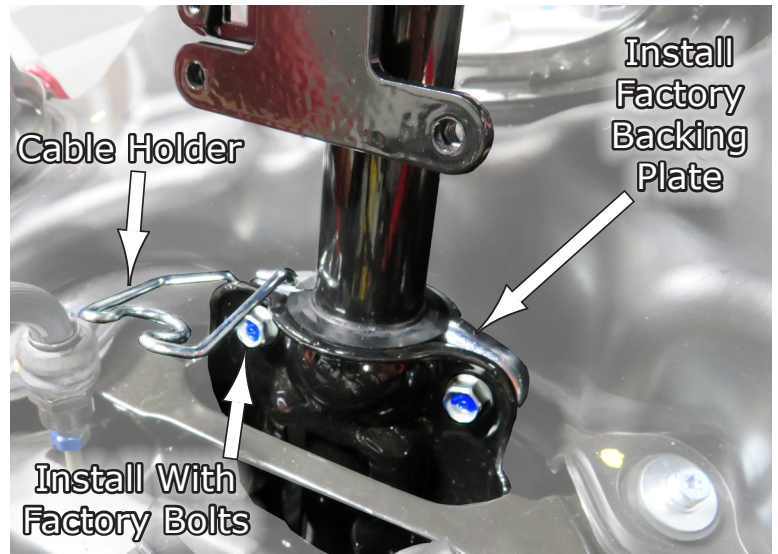


**Fig.22b**

23. Now go back up to the top end of the shaft as shown in **Fig.23a**, and install the **Backing Plate** and **Cable Holder** onto the shaft along with the **Factory Bolts** and tighten secure. See **Fig.23a-c**.



**Fig.23a**



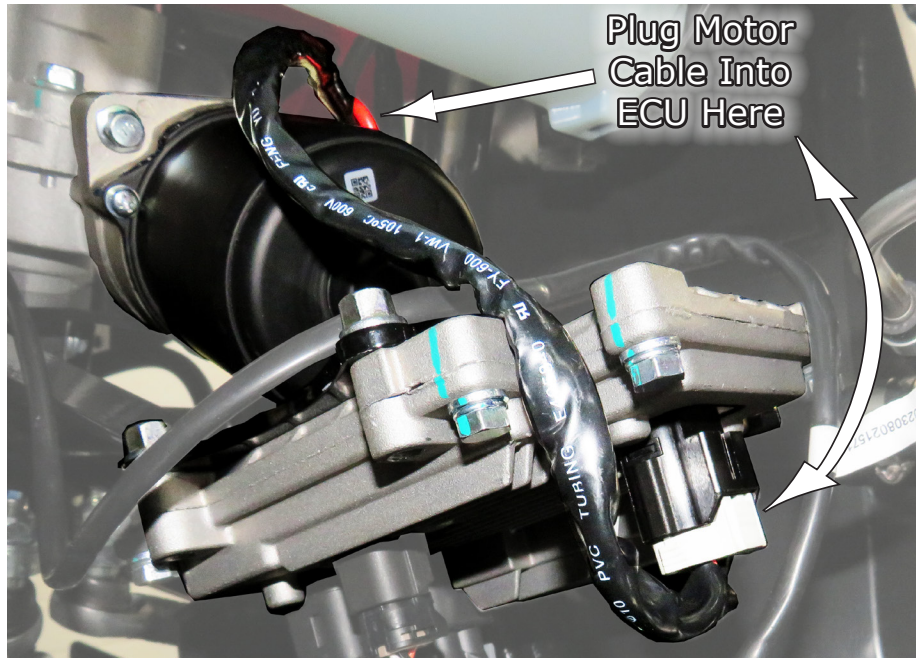
**Fig.23b**



**Fig.23c**



24. Now let's hook up the electronics of the kit. The first thing is to connect the **Steering Motor Power Cable** into the **ECU** as shown in **Fig.24**.



**Fig.24**

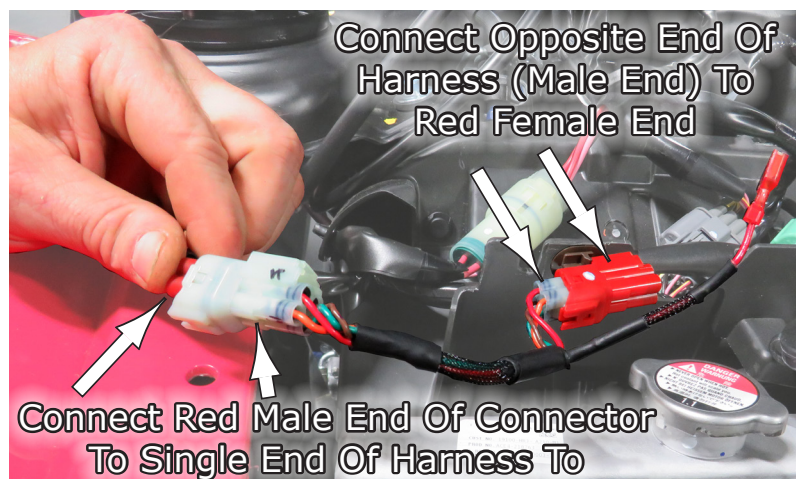
25. Next you will hook up the **Power Harness** from your kit. Right behind the radiator you will see a **RED factory connector** that is fixed to the wall as shown in **Fig.25a**. Now locate your **Power Harness** as shown in **Fig.25a**. Now unplug the factory **RED connector** and plug the Male End of the **RED connector** into the Female connector end of the **Power Harness**, and then the Male end of the **Power Harness** into the female end of the **RED connector** which is still attached to the wall as shown in **Fig.25b**.



**Power Harness**



**Fig.25a**



**Fig.25b**

26. Now find the **Cable Harness** that has the **White Wire** coming off of it, and the **Spade Terminal** all provided in your kit, and crimp or solder the terminal onto the White Wire as shown in **Fig.26**.

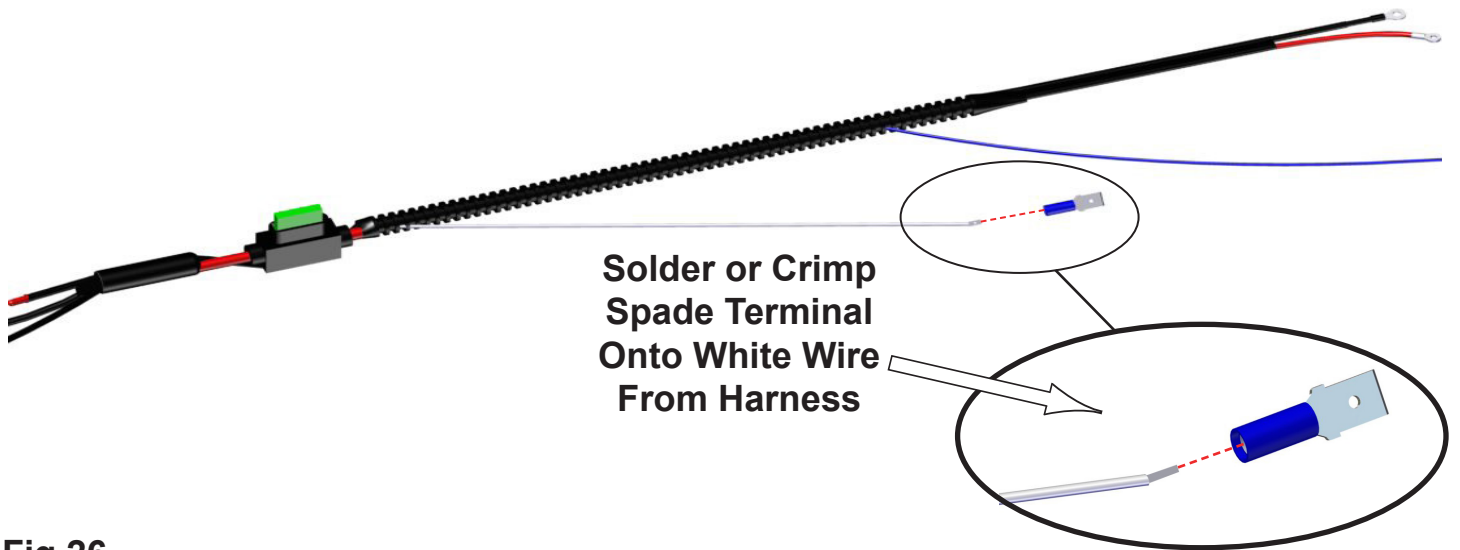


Fig.26

27. After the **Spade Terminal** is fixed on the **White Wire**, now plug the spade terminal into the last wire with the **Female Spade Terminal** coming from the harness you plugged into the RED connectors. **Fig.27a** shows them all hooked together, and **Fig.27b** shows a close-up of the Spade connection.

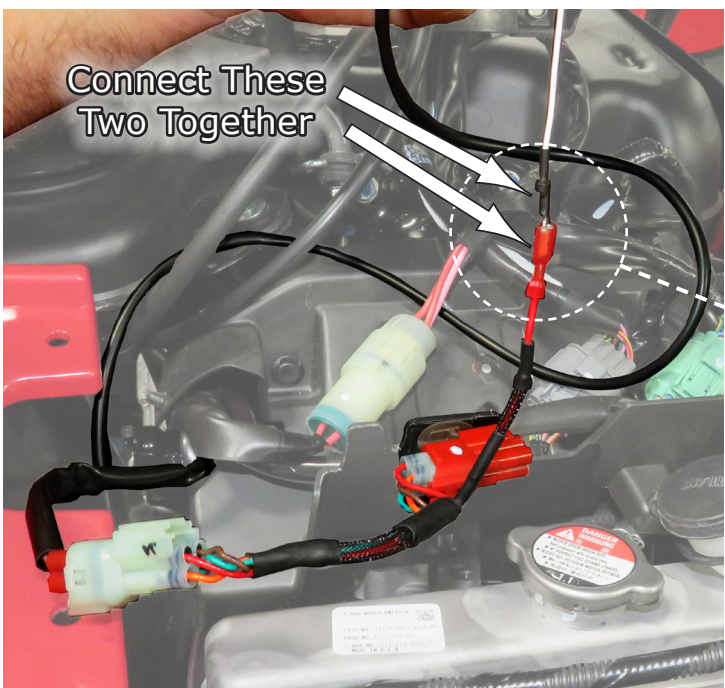


Fig.27a

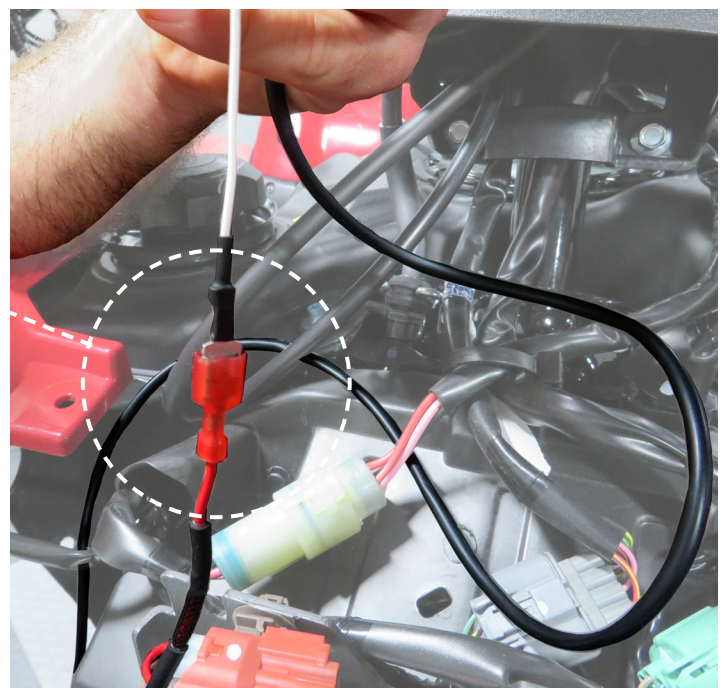
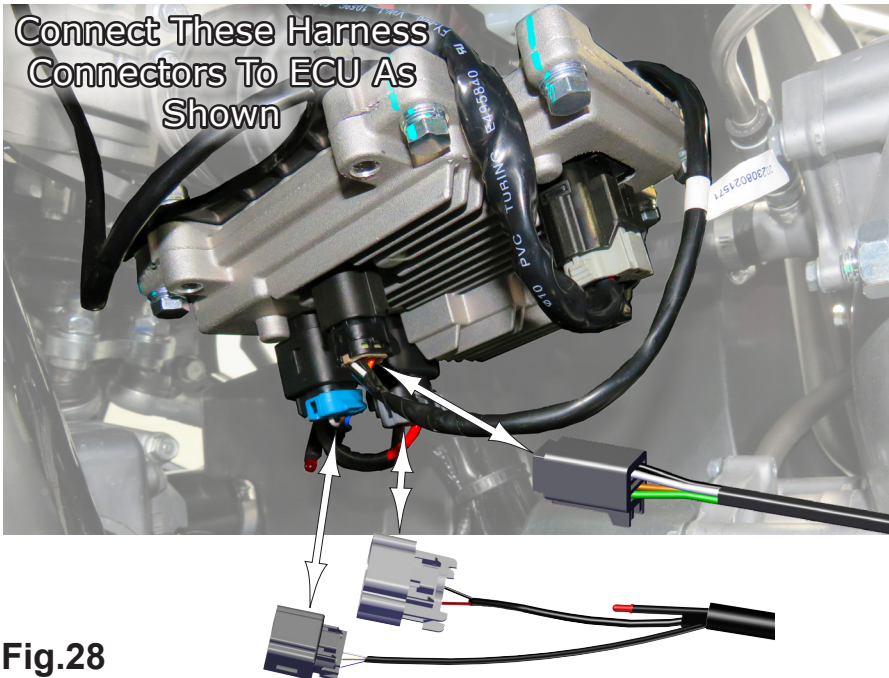


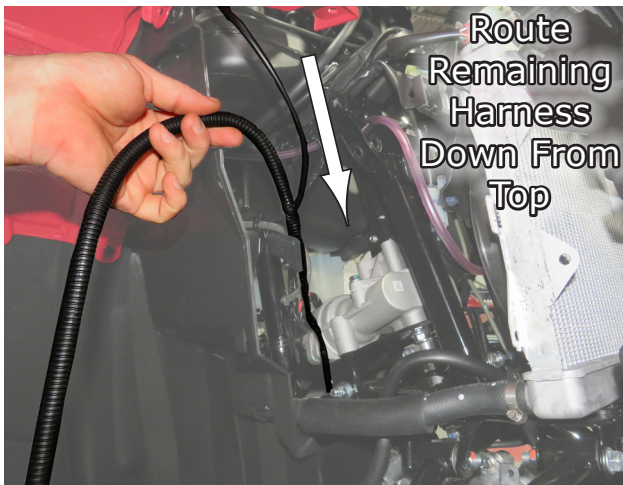
Fig.27b

28. Now find the two (2) connectors grouped together with the LED connected to it and White Wire you put the spade terminal on and plug those into the **ECU** as shown in **Fig.28**.



**Fig.28**

29. Once the ECU is all plugged in, now you will need to route the remaining harness back to the battery area. **Fig's 29a-c** show a good route path to get there. See **Fig.29a-c**. Then hook up the RED & BLACK wires from the harness to the battery terminals as shown in **Fig.29d**.



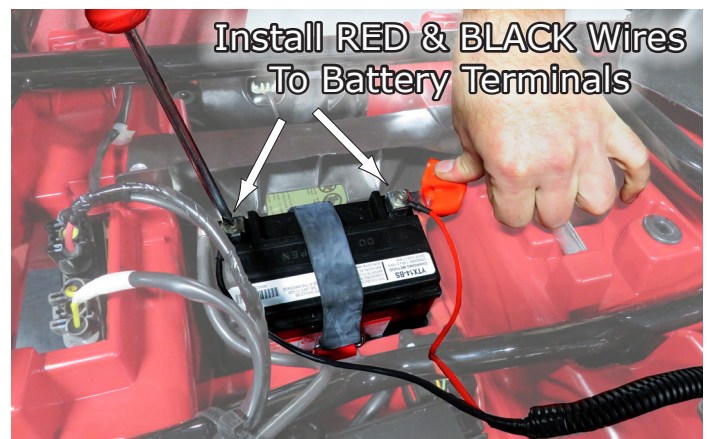
**Fig.29a**



**Fig.29b**



**Fig.29c**



**Fig.29d**

30. Now go back and re-install the handle bars and the brake line retainer as shown in Fig.30a-b. Then reinstall the Display and mounting assembly as shown in Fig.30c-d.

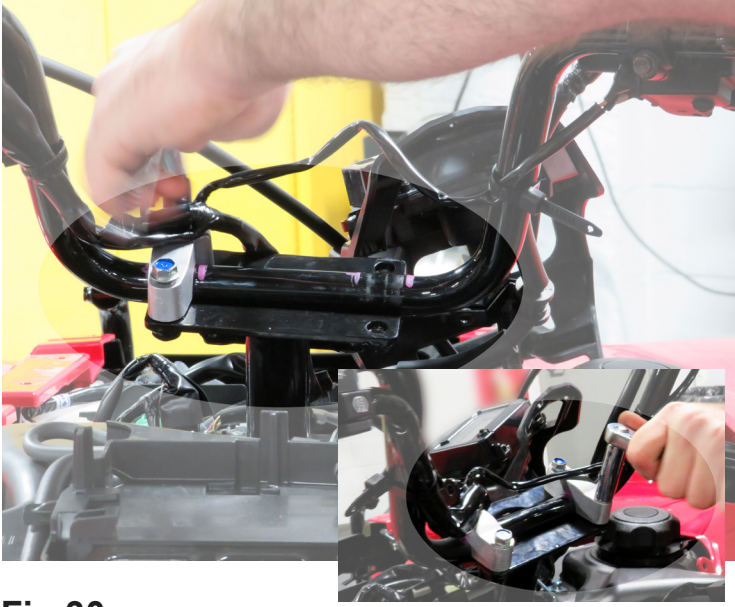


Fig.30a



Fig.30b



Fig.30c



Fig.30d

31. Then install the gauge cover as well. See Fig.31.

Continue to replace the shock and all body panels and seat back to original set-up to complete your new kit installation.



Fig.31





#### Liability Statement

SuperATV's® products are designed to best fit user's ATV/UTV under stock conditions. Adding, modifying, or fabricating any factory or aftermarket parts will void any warranty provided by SuperATV® and is not recommended. SuperATV's® products could interfere with other aftermarket accessories. If user has aftermarket products on machine, contact SuperATV® to verify that they will work together.

Although SuperATV® has thousands of satisfied customers, user should be aware that installing lift kits, long travel, or suspension kits, tires, etc. will change the ride of machine and may increase maintenance and part wear. Operating any off-road machine while, or after, consuming alcohol and/or drugs increases risk of bodily harm or death. No warranty or representation is made as to this product's ability to protect user from severe injury or death. SuperATV® urges operators and occupants to wear a helmet and appropriate riding gear at all times.

By purchasing and installing SuperATV® products, user agrees that should damages occur, SuperATV® will not be held responsible for loss of time, use, labor fees, replacement parts, or freight charges. SuperATV®, nor any 3rd party, will not be held responsible for any direct, indirect, incidental, special, or consequential damages that result from any product purchased from SuperATV®. The total liability of seller to user for all damages, losses, and causes of action, if any, shall not exceed the total purchase price paid for the product that gave rise to the claim.

SuperATV® will warranty only parts provided by SuperATV®. Any damage or problems with OEM housings, bearings, seals, or other manufacturers' products will not be covered by SuperATV®. SuperATV® parts and products are not warranted if item was not installed properly, misused, or modified.

Installing, adding, modifying, or fabricating any factory or aftermarket product to your ATV/UTV may violate certain local, state, and federal laws. Be advised that laws vary depending on town, city, county, state, etc. Use of certain products on public streets, roads, or highways may be in violation law. The Buyer is solely and exclusively legally and personally responsible for any violation of the law by the installation or use of the product. You must abide by all local, state, and federal laws, including but not limited to vehicle safety, traffic laws, and ordinances. It is your responsibility to know the laws and how they apply to you.

The Buyer is responsible to fully understand the capability and limitations of his/her vehicle according to manufacturer specifications, warnings and instructions and agrees to hold SuperATV® harmless from any damage resulting from failure to adhere to such specifications, warnings and/ or instructions. The Buyer is also responsible to obey all applicable federal, state, and local laws and ordinances when operating his/her vehicle while using this product, and the Buyer agrees to hold SuperATV® harmless from any violation thereof.

If you have any problems/questions on this kit, contact us by email at [superatv.com](mailto:sales@superatv.com).

#### Need help with your installation?



[sales@superatv.com](mailto:sales@superatv.com)



[www.superatv.com](http://www.superatv.com)



1-855-743-3427



8:00am - 9:00pm EST M-Th  
8:00am - 7:00pm EST Friday  
9:00am - 2:00pm EST Saturday

*Thank You  
For Choosing*



**Like SuperATV on Facebook to keep up to date on new products!**