



motoalliance



VIPER
— ***WINCHES*** —

VIPER V3 9000 LB Standard Winch
V39000_BK

INSTALLATION INSTRUCTIONS

Thank you for purchasing a VIPER Winch.
You now own a premium, winch to allow you to use your utility vehicle.
Please note the following instructions and heed all warnings.



- Your UTV and winch system can cause death or injury. Please use caution and common sense when operating your unit.
- Read the complete Winch Operator Manual and all warning labels before operating your UTV and winch system.
- Be observant of moving parts causing entanglement, use extreme caution!

SEVERE INJURY OR DEATH MAY RESULT IF YOU ARE NEGLIGENT.

PARTS LIST



Please verify that all hardware and parts are included in your package.

| Part# | Qty | Item Description |
|-------|-----|--------------------------------|
| 1 | 4 | Hexagon socket screw M6 x 50mm |
| 2 | 4 | Hexagon socket screw M6 x 12mm |
| 3 | 1 | Motor end cap |
| 4 | 1 | Motor |
| 5 | 1 | Brake |
| 6 | 3 | Bolt M4 x 8mm |
| 7 | 2 | Sliding bearing |
| 8 | 2 | Seal ring |
| 9 | 1 | Drum |
| 10 | 1 | Wire rope |
| 11 | 1 | Gearbox base |
| 12 | 1 | Ring gear |
| 13 | 1 | Drive shaft |
| 14 | 1 | Stage-3 of planetary gear |
| 15 | 1 | Washer |

| Part# | Qty | Item Description |
|-------|-----|---------------------------|
| 16 | 1 | Stage-2 of planetary gear |
| 17 | 1 | Spacer |
| 18 | 1 | Stage-1 of planetary gear |
| 19 | 1 | Washer |
| 20 | 1 | Fork pin |
| 21 | 1 | O ring |
| 22 | 1 | Housing |
| 23 | 1 | O ring |
| 24 | 1 | Gearbox |
| 25 | 1 | Clutch handle |
| 26 | 2 | Tie bar |
| 27 | 2 | Tie bar pin |
| 28 | 1 | Solenoid |
| 29 | 6 | Nut M8 |
| 30 | 2 | Nut M4 |
| 31 | 10 | Flat washer M8 |
| 32 | 2 | Flat washer M4 |

| Part# | Qty | Item Description |
|-------|-----|----------------------------|
| 33 | 10 | Lock washer M8 |
| 34 | 2 | Lock washer M4 |
| 35 | 8 | Hexagon screw M8 x 25 |
| 36 | 2 | Hexagon screw M4 x 30 |
| 37 | 6 | Terminal rubber boots |
| 38 | 2 | Hexagon screw M8 x 20 |
| 39 | 1 | Mounting plate |
| 40 | 1 | Roller fairlead |
| 41 | 1 | Instruction manual |
| 42 | 1 | Mini rocker switch bracket |
| 43 | 1 | Hand strap |
| 44 | 1 | Hook |
| 45 | 1 | Mini rocker switch |
| 46 | 1 | Battery cable + |
| 47 | 1 | Battery cable - |
| 48 | 1 | Solenoid cable (yellow) |
| 49 | 1 | Solenoid cable (blue) |

PARTS DIAGRAM

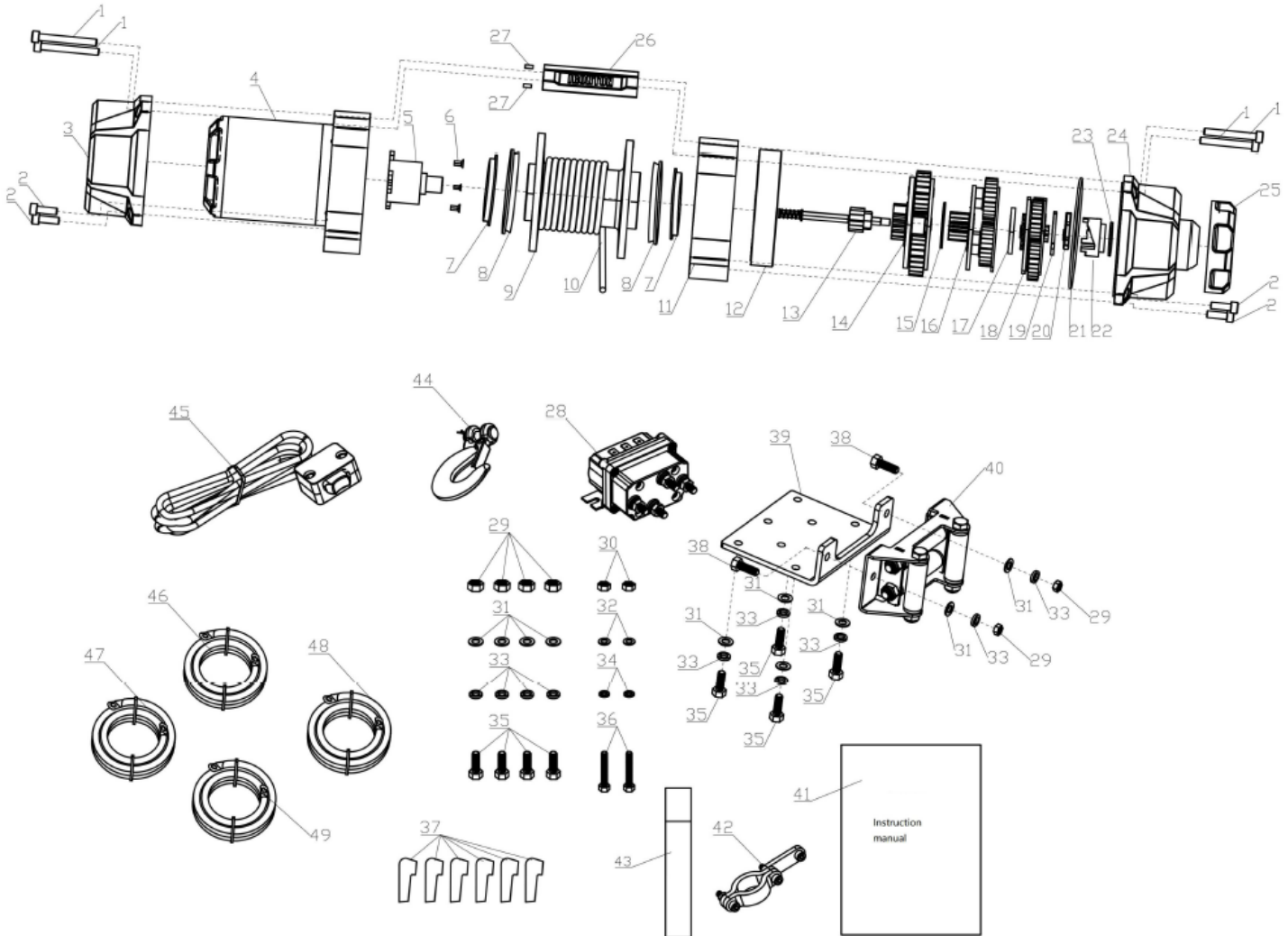

TABLE OF CONTENTS

| | |
|------------------------------------|---|
| Intended Use | 4 |
| Technical Specifications | 4 |
| Important Safety Information | 5 |
| Specific Operation Warnings | |
| Assembly Instructions | |
| Before Each Use | |
| Operating Instructions | |
| After Each Use | |
| Maintenance | |

INTENDED USE

This DC 12V electric winch is ideal for Trailers and UTV vehicles. With an automatic loadholding brake, loads are kept under tension while in use.













TECHNICAL SPECIFICATIONS

| Property | Specification |
|----------------------|-----------------------------------------|
| Motor | 12 Volt DC, 4.2 HP permanent magnet |
| Rated line pull | 9000lbs (4091 kgs) |
| Application | Utility/ Trailer/ UTV |
| Power in & power out | Yes |
| Control switch | Wired remote switch and wireless remote |
| Gear train | 3 stage planetary |
| Gear ratio | 278:1 |
| Free spool | Yes |
| Brake | Automatic, full load holding |
| Drum size (Dia x L) | 2.28in x 5in (58mm x 127mm) |
| Hook | 3/8" clevis hook |
| Rope size | 0.335in x 44.3 ft (8.5mm x 13.5m) |
| Battery | Minimum 650 CCA |

| Layer | Rated line pull (lbs/kgs) | Wire rope capacity (ft/m) |
|-------|---------------------------|---------------------------|
| 1 | 9000/4082 | 10/3.1 |
| 2 | 7167/3250 | 21.6/6.6 |
| 3 | 5955/2701 | 34.4/10.5 |
| 4 | 5093/2310 | 44.2/13.5 |

| Line pull (lbs/kgs) | Line speed (fpm/mpm) | Motor Amps |
|---------------------|----------------------|------------|
| 0 | 18/5.5 | 39 |
| 2250/1021 | 6.1/6.6 | 82 |
| 4500/2041 | 4.72/1.44 | 145 |
| 6750/3062 | 3.87/1.18 | 210 |
| 9000/4082 | 3.2/1 | 250 |

IMPORTANT SAFETY INFORMATION

| Symbol | Property or Statement | Symbol | Property or Statement |
|-------------------------------------------------------------------------------------|--------------------------------------------------------------------------------------------------|-----------------------------------------------------------------------------------|---------------------------------------------------------------------------------------------------------------------------------------------------------------|
|  | Wear heavy-duty, cut- and abrasion-resistant leather gloves. |  | Do not use winch in overwind orientation. (Wire rope enters/exits at the top.) |
|  | Wear ANSI-approved safety glasses. |  | Use winch only in underwind orientation. (Wire rope enters/exits at the bottom.) |
|  | Cut or sever hazard. | VDC | Volts Direct Current |
|  | Roller entanglement hazard. | A | Amperes |
|  | Hot surface burn hazard. | CCA | Cold Cranking Amperes |
|  | Fire hazard. | HP | Horsepower |
|  | Caustic chemical hazard from battery acid. | fpm | Feet Per Minute |
|  | Explosion hazard. | mpm | Meters Per Minute |
|  | Do not loop the wire rope around object and hook onto itself. | RPM | Revolutions Per Minute |
|  | Do not place finger(s) through hook. Fingers may be caught and get pulled into fairlead or drum. | IP | International Protection rating Classifies the degrees of protection provided against the intrusion of solid objects, dust, accidental contact, and water. |
|  | Pull hook using strap only. | G8 | Grade 8 A fastener strength rating. |

WARNING

- Read and understand all instructions. Failure to follow all instructions may result in serious injury or property damage.
- The warnings, cautions, and instructions in this manual cannot cover all possible conditions or situations that could occur. Exercise common sense and caution when using this tool. Always be aware of the environment and ensure that the tool is used in a safe and responsible manner.

-
- Do not allow persons to operate or assemble the product until they have read this manual and have developed a thorough understanding of how it works.
 - Do not modify this product in any way. Unauthorized modification may impair the function and/or safety and could affect the life of the product. There are specific applications for which the product was designed.
 - Use the right tool for the job. DO NOT attempt to force small equipment to do the work of larger Page 11 of 27 industrial equipment. There are certain applications for which this equipment was designed. This product will be safer and do a better job at the capacity for which it was intended. DO NOT use this equipment for a purpose for which it was not intended.
 - Industrial or commercial applications must follow OSHA requirements.

WORK AREA SAFETY

- Inspect the work area before each use. Keep work area clean, dry, free of clutter, and well-lit. Cluttered, wet, or dark work areas can result in injury. Using the product in confined work areas may put you dangerously close to cutting tools and rotating parts.
- Do not use the product where there is a risk of causing a fire or an explosion, e.g., in the presence of flammable liquids, gases, or dust. The product can create sparks, which may ignite the flammable liquids, gases, or dust.
- Do not allow the product to come into contact with an electrical source. The tool is not insulated and contact will cause electrical shock.
- Keep children and bystanders away from the work area while operating the tool. Do not allow children to handle the product.
- Be aware of all power lines, electrical circuits, water pipes, and other mechanical hazards in your work area. Some of these hazards may be hidden from your view and may cause personal injury and/or property damage if contacted.

PERSONAL SAFETY

- Stay alert, watch what you are doing, and use common sense when operating the tool. Do not use the tool while you are tired or under the influence of drugs, alcohol, or medication. A moment of inattention while operating the tool may result in serious personal injury.
- Dress properly. Do not wear loose clothing, dangling objects, or jewelry. Keep your hair, clothing and gloves away from moving parts. Loose clothes, jewelry, or long hair can be caught in moving parts. Air vents on the tool often cover moving parts and should be avoided.

- Wear the proper personal protective equipment when necessary. Use ANSI Z87.1 compliant safety goggles (not safety glasses) with side shields, or when needed, a face shield. Use a dust mask in dusty work conditions. Also use non-skid safety shoes, hardhat, gloves, dust collection systems, and hearing protection when appropriate. This applies to all persons in the work area.
- Do not overreach. Keep proper footing and balance at all times.

PRODUCT USE AND CARE

- Do not force the product. Products are safer and do a better job when used in the manner for Page 12 of 27 which they are designed. Plan your work and use the correct product for the job.
- Check for damaged parts before each use. Carefully check that the product will operate properly and perform its intended function. Replace damaged or worn parts immediately. Never operate the product with a damaged part.
- Do not use a product with a malfunctioning switch. Any power tool that cannot be controlled with the power switch is dangerous and must be repaired by an authorized service representative before using.
- Disconnect the power/air supply from the product and place the switch in the locked or off position before making any adjustments, changing accessories, or storing the tool. Such preventive safety measures reduce the risk of starting the tool accidentally.
- Store the product when it is not in use. Store it in a dry, secure place out of the reach of children. Inspect the tool for good working condition prior to storage and before re-use.
- Use only accessories that are recommended by the manufacturer for use with your product. Accessories that may be suitable for one product may create a risk of injury when used with another tool. Never use an accessory that has a lower operating speed or operating pressure than the tool itself.
- Keep guards in place and in working order. Never operate the product without the guards in place
- Do not leave the tool running unattended.
- Do not wear loose clothing or jewelry, as they can be caught in moving parts. Non-skid footwear is recommended. Wear restrictive hair covering to contain long hair.
- Wear ANSI-approved safety goggles and heavy-duty leather works gloves during installation.
- Before installation confirm that area is clear of fuel lines, brake lines, electrical wires, gas tanks or any other component which could be damaged during drilling.
- Mounting location and hardware must support winch and load.

- Use supplied power cords and wire rope listed in manual only. Do not use thinner / longer cables or link multiple cables together.
- Do not route electrical cables near sharp edges or parts that will move or become hot.
- Ventilate area well before and while working on battery. Explosive invisible hydrogen gas can accumulate and then explode when ignited by a spark from the battery connection.
- Only connect to a clean, corrosion free battery.
- Do not lean over or come in contact with battery while making connections.
- Remove all metal jewelry before working near battery.
- Connect red wire to positive battery terminal and black wire to negative battery terminal.
- Insulate all exposed wiring and terminals after installation.
- Install winch and fairlead in underwind orientation, so that the wire rope enters and exits the winch at the bottom of the drum.

Specific Operation Warnings

- Do not exceed load capacity. Be aware of dynamic loading. Sudden load movement may briefly create excess load causing product failure.
- Do not maintain power to the winch if the motor stalls. Verify load is within rated capacity for the wire rope layer, see WINCH SPECIFICATIONS.
- Make sure the battery is fully charge.
- Use double line rigging whenever possible.
- Wear ANSI-Approved safety goggles and heavy-duty leather work gloves during operation.
- Do not disengage clutch under load. Engage clutch before starting.
- Keep clear of fairlead when operating. Do not try to guide wire rope.
- Do not place finger through hook. Finger may be caught and get pulled into fairlead or drum. Use included strap to hold hook instead.
- Place heavy rag or carpet over wire rope span 6 feet from hook to help absorb the force released if the wire rope breaks (see figure A)



Figure A: Whiplash Dampening Blanket or Rug

- Stay out of the direct line that the wire rope is pulling. In case it slips or breaks, it will “whiplash” along this line.
- Do not use for lifting or moving people.
- Use a spotter to assist you in assuring that it is safe to operate the winch. Make sure the spotter is out of the way of the vehicle and the wire rope before activating the winch.
- Do not use vehicle to pull on the wire rope and “assist” the winch.
- Use as intended only. Do not lift items vertically or use for aircraft purposes.
- Prevent entanglement, do not wear loose clothing or jewelry, as they can be caught in moving parts. Non-skid footwear is recommended. Wear restrictive hair covering to contain long hair.
- Disconnect pendant controller before working near the wire rope, drum, fairlead, or load, to prevent accidental starting.
- Inspect before every use, do not use if damaged or parts loose. Examine the winch for structural cracks, bends, damage, frayed or kinked wire rope, and any other conditions that may affect the safe operation of the winch. Do not use the winch even if minor damage appears. A kink permanently weakens the wire rope, even after it is straightened out, kinked wire rope can fail suddenly and must not be used.
- Keep wire rope straight to avoid kinking the wire rope. The illustrations to the right show how a kink form.

This illustration shows a kink about to form. At this point the winch should be stopped and the wire ropes should be straightened out to prevent kinking.



This wire rope is kinked. It is too late to reverse the damage at this point, the wire rope must be discarded. It is permanently damaged and must not be used.



This is a kinked wire rope that has been straightened out. Even though it has been pulled straight, some wires in the wire rope are stretched, and others are severely bent, if not broken. The unstretched wires will take more load and can fail suddenly before the rope reaches its capacity. This wire rope must be discarded and not be used.



A kink permanently weakens the wire rope, even after it is straightened out; kinked wire rope can fail suddenly and must not be used.

- Keep children and bystanders away while operating, distractions can cause you lose control.
- Stay alert, watch what you are doing and use common sense when operating. Do not use a winch while you are tired or under the influence of drugs, alcohol or medication. A moment of inattention while operating winches may result in serious personal injury.
- Do not overreach. Keep proper footing and balance at all times. This enables better control of the winch in unexpected situations.
- Do not use a recovery strap while winching. They are designed to stretch and can suddenly whip back towards the operator during a winching operation.

- Secure load after moving. **NO LOCKING MECHANISM**
- Keep at least 8 turns of wire rope on drum. The wire rope's connection to the drum is not intended to sustain a load. Without the added support from the friction of at least 8 full turns of wire rope.
- Wrap wire rope under 500lbs, tension before use. Otherwise, wire rope may bind during operation
- Keep clear of wire rope, hook and load while winching. Do not step over wire rope. Do not push sideways against wire rope under tension; wire rope might break under this load and recoil back, striking the person pushing against it or a bystander.
- If wire rope begins to get entangled, stop winch immediately and release wire rope using switch.
- Do not submerge winch in water. If winch gets submerged accidentally, it needs to be immediately disassembled, cleaned, dried and re-lubricated by a qualified technician to prevent permanent damage from corrosion.
- Only winch with the winching vehicle's transmission in neutral. Winching with a vehicle's transmission in gear or park may damage the transmission. A vehicle's transmission is not designed to handle that type of load.
- Do not operate the winch at extreme angles. Do not exceed the angles shown in Figure B for a roller fairlead. For a hawse fairlead, the angle should be as close to straight as possible.

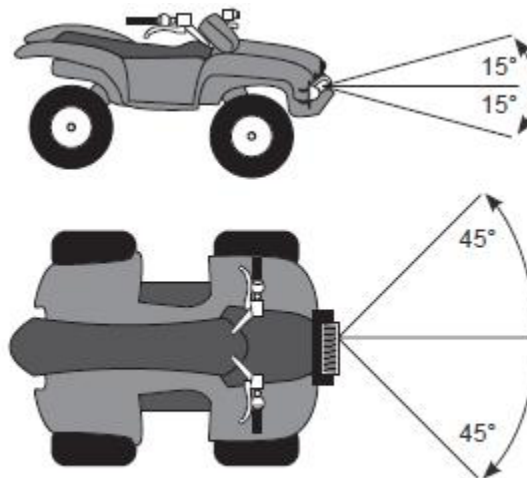

Figure B: Roller fairlead Maximum Winching Angles

- If the object to be pulled must be pulled at an angle in relation to the winch, use a pulley (sold separately) and an anchor point directly in front of the winch, as shown in Figure C, to keep the wire rope pull straight.

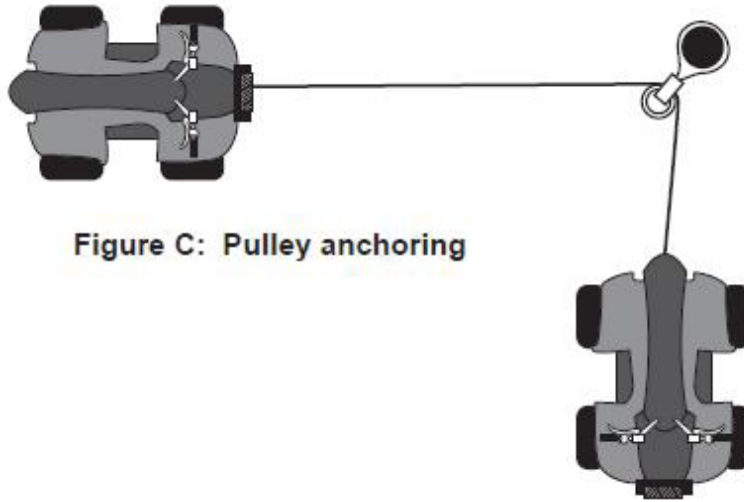

Figure C: Pulley anchoring

- Broken strands of wire rope will be sharp. Wear heavy-duty work gloves when handling the wire rope. Do not slide wire rope through hands, even with gloves on.
- Winch motor will be hot during and after use. Keep clear.
- Do not power the hook all the way into the fairlead or winch.
- People with pacemakers should consult their physician before use. Electromagnetic fields in close proximity to heart pacemaker could cause pacemaker interference or pacemaker failure.
- Wear ANSI-approved safety goggles and heavy-duty leather work gloves during service.
- Disconnect power to winch and allow it to cool completely before service.
- Use supplied power cords / wire rope or cables listed in manual only. Do not use thinner / longer cables or link multiple cables together.
- Have the winch serviced by a qualified repair person using only identical replacement parts. This will ensure that the safety of the winch is maintained.

ASSEMBLY INSTRUCTIONS

- The mounting plate must be rated to at least the winch's capacity.
- Align the winch perpendicular to center line of the vehicle at the desired location and mark the locations of the winch base holes. Compare the dimensions of the marked holes to Figure D

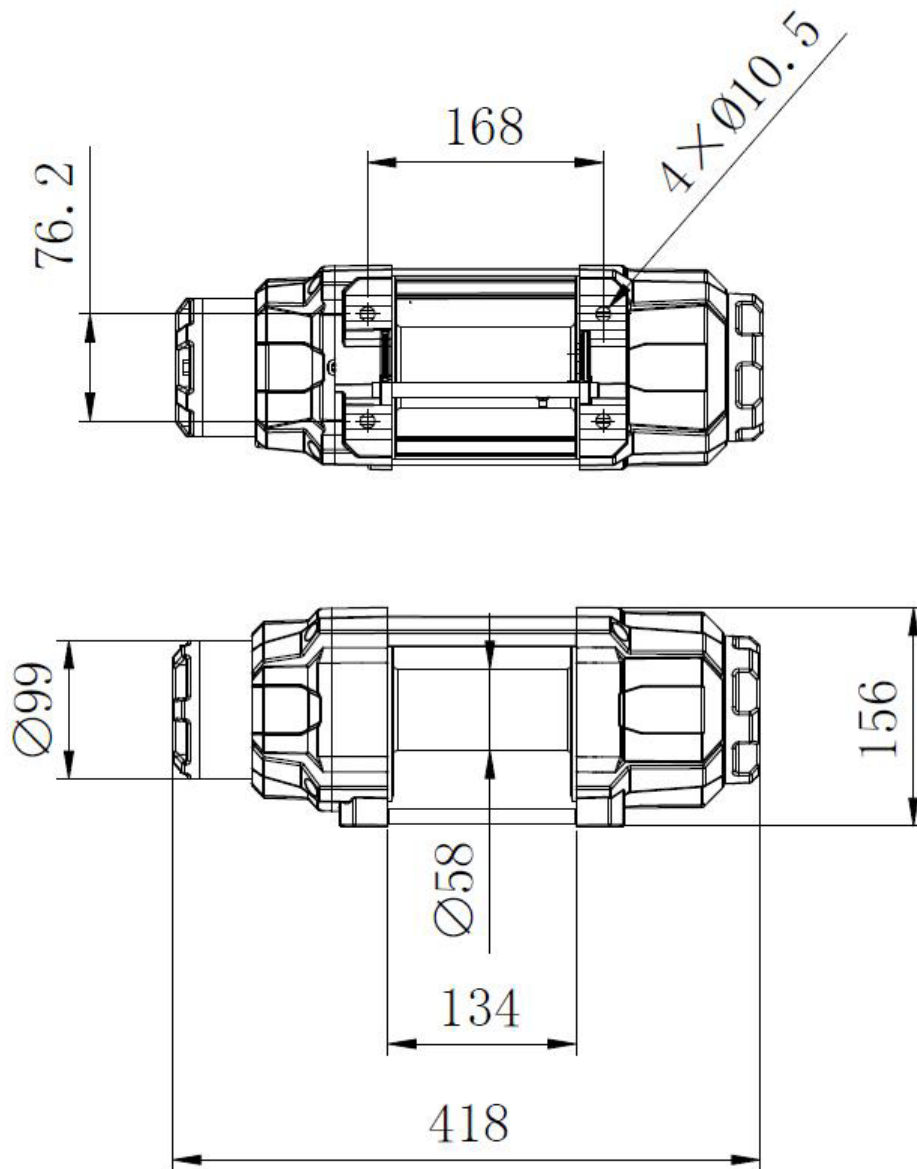

Figure D

- Before drilling, verify that the installation surface has no hidden components or structural pieces that will be damaged.

NOTE: this winch can generate extreme forces. Select a location that can withstand the rated capacity without damage or weakening. Steel reinforcement plates may be needed or a certified welder maybe need to weld on additional bracing depending on the mounting location.

- Drill holes appropriate for the hardware at the marked locations.
- Install the winch using the hardware specified on the specification chart.

Mounting the Winch Components

- Mount the solenoid box in proper location so that:
 - a. Winch components are close enough to each other to allow wires to be routed properly.
 - b. Vehicle component operation is not interfered with.
 - c. Vehicle components are not damaged by drilling or driving screws.
 - d. Winch components will not be damaged by stresses caused by vehicle operation.
- Mark the locations where the screw holes will be.
- Verity that the installation surface has no hidden components or structural pieces that will be damaged before drilling.
- Drill pilot holes for the mounting screws.
- Secure in place with mounting screws.

Wiring

- Plan a route for the wiring from the point of the vehicle where the winch will be mounted, or used, to the battery. This route must be secure, out of the way of moving parts, road debris, or any possibility of being damaged by operation or maintenance of the vehicle. For example, you may wish to route the wires under the vehicle, attaching it to the frame using suitable fasteners. Do not attach the wires to the exhaust system, drive shaft, emergency brake cable, fuel line, or any other components which may create damage the wiring through heat or motion, or create a fire hazard.
- If you drill through the bumper or any part of the body to route the wires, be sure to install a rubber grommet in the hole to prevent fraying of the wires at that point.
- Route the cables from the solenoid to the battery and from the solenoid to the winch, following the precautions discussed above, see Figure E.

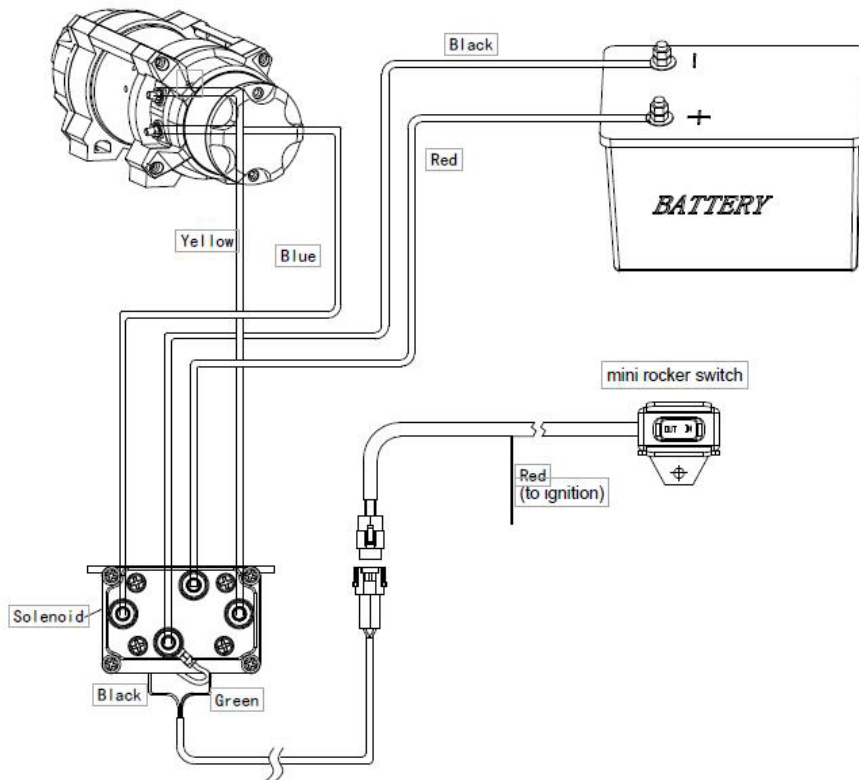

Figure E

- Attach the wires from the solenoid box to the terminals on the winch.
- Attach the black battery cable directly to the negative terminal of the battery.

Note:

The attachment of the motor cables determines the direction of the pendant controller's button. After the unit is mounted and powered, check the direction of the power IN and power OUT on the pendant controller button, if you wish to change the direction on the pendant controller, disconnect the battery cables from the battery, switch the motor cable connections on the motor assembly, then reconnect the battery cables.

Preparing the Wire Rope

- The wire rope must be properly coiled under tension to be able to support a load without damage.
- Uncoil the wire rope, except for 5 full wraps.
- Recoil the wire rope back into the winch under at least 500 lbs of tension.

Clutch Operation

- Do not adjust the clutch unless there is no load on the wire rope.
- To engage the clutch, turn the clutch knob clockwise completely until it stops, see Figure F



Figure F

BEFORE EACH USE

Warning

- Read the ENTIRE IMPORTANT SAFETY INFORMATION section at the beginning of this manual including all text under subheadings therein before setting up or use of this product.
- The instructions that follow are basic guidelines only and cannot cover all situations encountered during use. The operator and assistants must carefully plan usage to prevent accidents.

1. Examine the wire rope. Do not use the winch if the wire rope is frayed, kinked or damaged.
2. Fully charge the vehicle's battery.
3. Check the winch's electrical connections, all connections must be tight and clean.
4. Put the vehicle's transmission in neutral.
5. If the vehicle where the winch is mounted is not supposed to be moved, engage the emergency brake and block the wheels using wheel chocks (sold separately).
6. To pull out the wire rope, move the clutch handle to the released position, slide the loop of the hook strap over the hook, then pull on the hook strap to pull out the wire rope.

Leave at least 5 full turns of wire rope on the drum.

7. Hook onto the object using a pulling point, tow strap, tree strap, or chain, see Figure G.



Figure G: Using a strap anchor point

8. Do not wrap the rope around the object and hook onto the rope itself.
9. Attachment point must be centered in loop of hook and the hook's safety clasp must be fully closed. See Figure H.

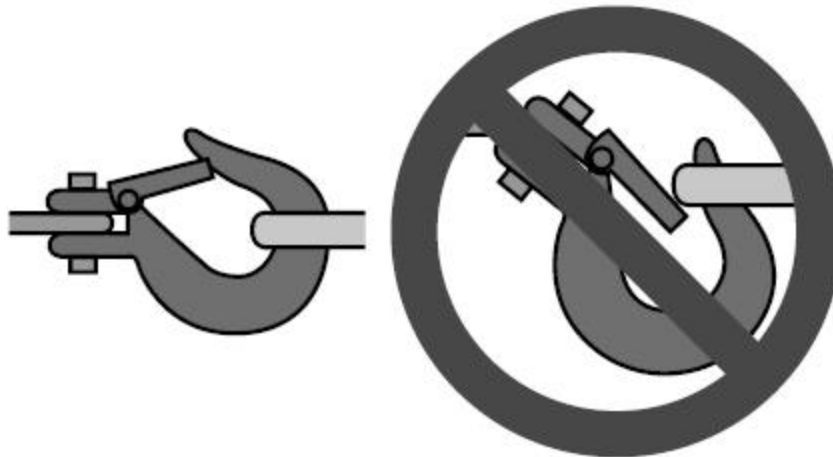

Figure H: Correct and incorrect hook attachment

10. Do not use a recovery strap while winching. They are designed to stretch and can suddenly whip back towards the operator during a winching operation.
11. Place a heavy rag or carpet (sold separately) over the wire rope span, 6 feet from the hook to help absorb the force released if the wire rope breaks.



Figure A: Whiplash Dampening Blanket or Rug

12. Move the clutch control to the engaged position, see the instructions for your winch model under clutch operation.
13. When it is safe to do so, use the power switch on the pendant controller to retract the wire rope, and winch the item as desired. Do not power the hook all the way into the fairlead to prevent damage.
14. Do not operate the winch at extreme angles. Do not exceed the angles shown in Figure B for a roller fairlead. For a hawse fairlead, the angle should be as close to straight as possible.

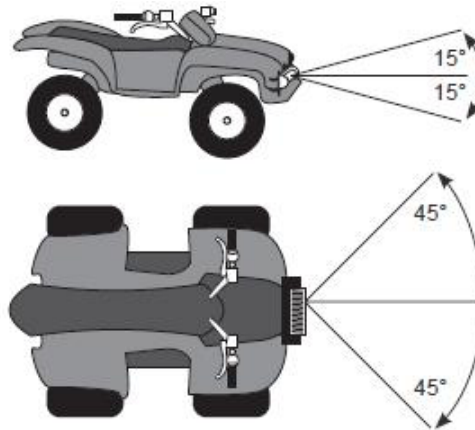

Figure B: Roller fairlead Maximum Winching Angles

15. If the object to be pulled must be pulled at an angle in relation to the winch, use a pulley (sold separately) and an anchor point directly in front of the winch, as shown in Figure C, to keep the wire rope full straight.

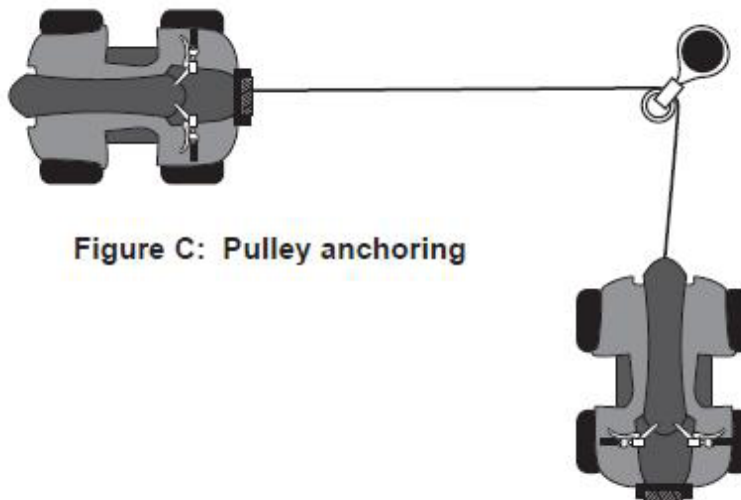

Figure C: Pulley anchoring

16. **WARNING!** Stop the winch and release tension on the wire rope before moving the rag or carpet placed on it.
17. Do not continue use of the winch until the battery is completely run down.
18. You may wish to keep the engine running while using this winch, to continually recharge the battery, however, exercise extreme caution when working around a running vehicle and **ONLY** operate a vehicle in an outdoor area.

19. **CAUTION:** do not use the winch in a constant duty application, it is designed for **INTERNITTENT USE ONLY**. Keep the duration of the pulling job as short as possible, if the motor becomes very hot to the touch, stop and let it cool down for several minutes. Do not pull load. Do not maintain power to the winch if the motor stalls. Double line rigging will help prevent overloading and should be used whenever practical.
20. When finished pulling the load, reverse the direction of the winch just enough to release tension on the wire rope so that you can unfasten the hook from the load and reel in the wire rope.

Operating Instructions

- **Duty Cycle (duration of use)**

Avoid damage to the winch by not winching for more than prescribed duty cycle time. The duty cycle defines the amount of time, within 15 minutes period, during which a winch can operate at its maximum capacity without overheating. For example, this winch with a 5% duty cycle at its maximum load must be allowed to rest for at least 14 minutes, 15 seconds after every 45 seconds of continuous operation. Failure to carefully observe duty cycle limitations can easily over-stress a winch contributing to premature winch failure.

After Each Use

- To prevent serious injury from winch failure: do not use damaged equipment. If abnormal noise or vibration occurs, have the problem corrected before further use.

Maintenance

- To prevent serious injury from accidental operation: unplug the pendant connector and disconnect the battery cables before performing any inspection, maintenance, or cleaning procedures.

Maintain the product by adopting a program of conscientious repair and maintenance in accordance with the following recommended procedures. It is recommended that the general condition of any tool be examined before it is used. Keep your tool in good repair. Keep all cutting tools sharp and clean. Properly maintained cutting tools with sharp cutting edges are less likely to bind and are easier to control. Keep handles dry, clean, and free from oil and grease. Also refer to the engine manufacturer's instruction manual for additional information about engine maintenance. The following chart is based on a normal operation schedule.

1. Before each use, inspect the general condition of the winch. Check for loose hardware, misalignment or binding of moving parts, cracked or broken parts, damaged electrical wiring, corroded or loose terminals, and any other condition that may affect its safe operation. Examine the wire rope. Do not use the winch if the wire rope is frayed, kinked or damaged.
2. After use, wipe external surfaces of the winch with clean cloth.
3. Lubricate the wire rope occasionally with a light oil.

4. The winch's internal mechanism is permanently lubricated. Do not open the housing. However, if the winch is submerged, it should be opened, dried, and re-lubricated by a qualified technician as soon as possible to prevent corrosion.
- Follow all safety precautions whenever diagnosing or servicing the tool. Disconnect power supply before service.

| Failure | Possible Cause | Corrective Action |
|---------------------------------------------|------------------------------------------------------------------------------------------------------------------------------------------------------------------------------------------------------------------------------------------------------------------------------------------------------------------------------------------------------------------------------------------------------------------------------------------------------------------|-------------------------------------------------------------------------------------------------------------------------------------------------------------------------------------------------------------------------------------------------------------------------------------------------------------------------------------------------------------------------------------------------------------------------------------------------------------------------------------------------------------------------------------------------------------------------------------------------------------------------------------------------------------------------------------------------|
| Motor Overheats | <ul style="list-style-type: none"> Incorrect power cords. Winch running time too long. | <ul style="list-style-type: none"> Use only supplied power cords. Allow winch to cool down periodically. |
| Motor Does Not Turn On | <ul style="list-style-type: none"> Switch assembly not connected properly. Loose battery cable connections. Vehicle battery needs charging. <ul style="list-style-type: none"> Solenoid malfunctioning. Defective switch assembly. <ul style="list-style-type: none"> Defective motor. Water has entered motor. Internal damage or wear. | <ul style="list-style-type: none"> Insert switch assembly all the way into connector. Tighten nuts on all cable connections. <ul style="list-style-type: none"> fully charge battery. Tap solenoid to loosen contacts. Apply 12 volts to coil terminal directly. A clicking indicates proper activation. Replace switch assembly. Check for voltage at armature port with switch pressed. If voltage is present, replace motor. <ul style="list-style-type: none"> Allow to drain and dry. Run in short bursts without load until completely dry. Have technician service winch. |
| Motor runs but wire rope drum does not turn | Clutch not engaged. | Move the clutch handle to the engaged position. If problem persists, a qualified technician needs to check and repair. |
| Motor runs slowly or without normal power | <ul style="list-style-type: none"> Insufficient current or voltage. Loose or corroded battery cable connections. Incorrect power cords. | <ul style="list-style-type: none"> Battery weak, recharge. Run winch with vehicle motor running. <ul style="list-style-type: none"> Clean, tighten or replace. Use only supplied power cords. |
| Motor runs in one direction only | <ul style="list-style-type: none"> Defective or stuck solenoid Defective switch assembly | <ul style="list-style-type: none"> Tap solenoid to loosen contacts, repair or replace solenoid. <ul style="list-style-type: none"> Replace switch assembly. |