

INSTALLATION INSTRUCTIONS
3" - 5" Lift Kit
 for Polaris RZR[®] XP

Item	Description	Qty	Item	Description	Qty
A	Front Bracket (Aft)	1	T	35mm Lg. Spacer	1
B	Front Bracket (Fore)	1	U	30mm Lg. Spacers	2
C	Rear Shims	2	V	25mm Lg. Spacers	2
K	Tie Rod Ends	2	W	31mm Lg. Spacers	4

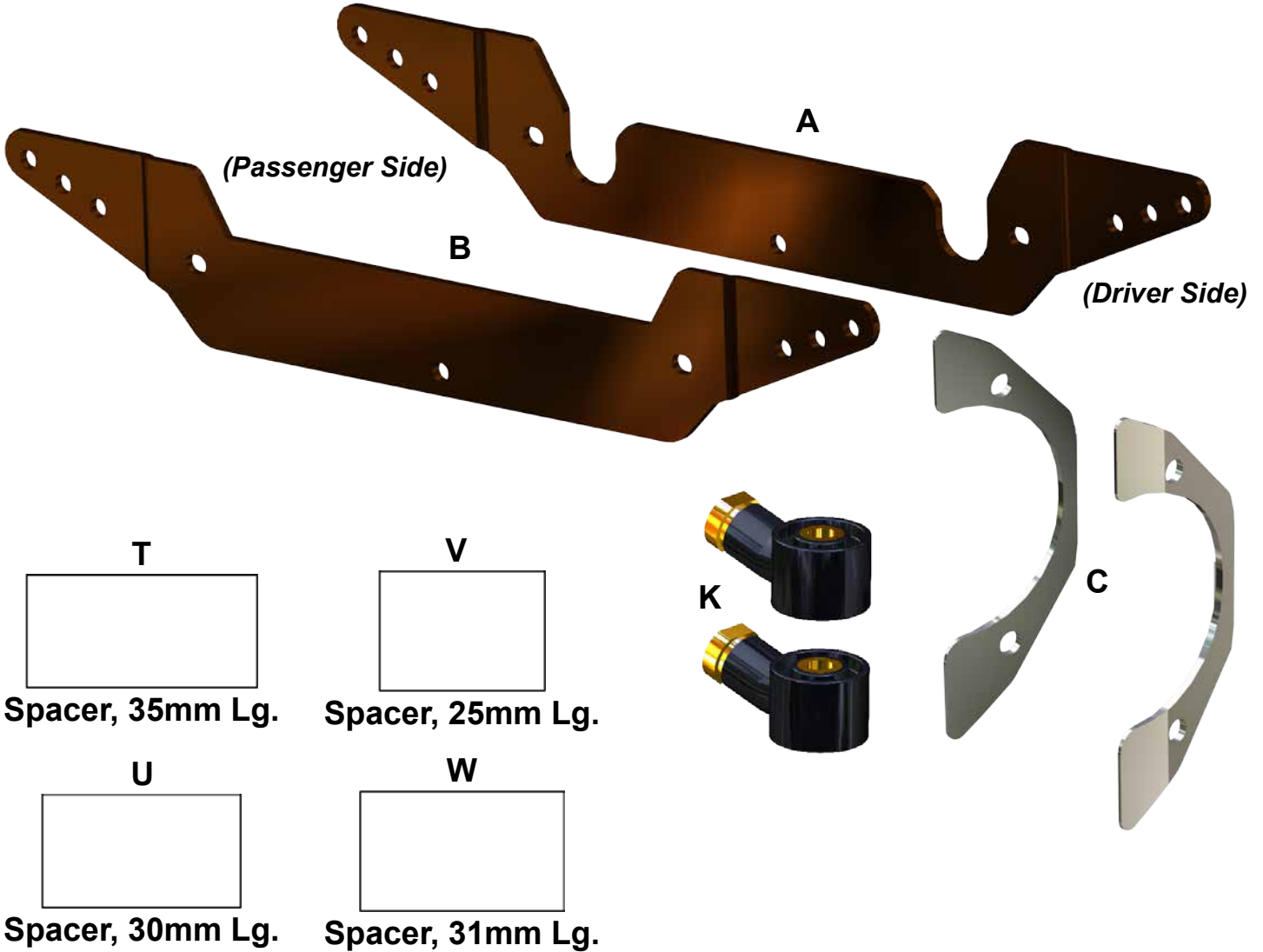

(Kit contents continue on following page)

Need help with your installation?

 sales@superatv.com
  www.superatv.com

 1-855-743-3427
  8:00am - 9:00pm EST M-Th
 8:00am - 7:00pm EST Friday
 9:00am - 2:00pm EST Saturday

Read instructions and view illustrations before beginning.

Thank You
For Choosing
SUPERATV.COM[®]

(kit contents continued)

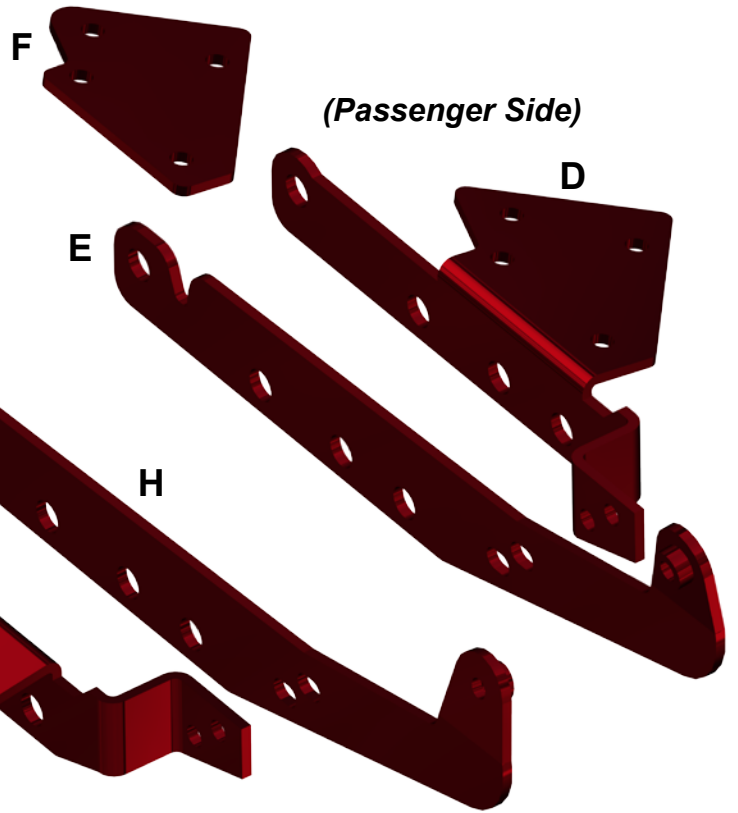
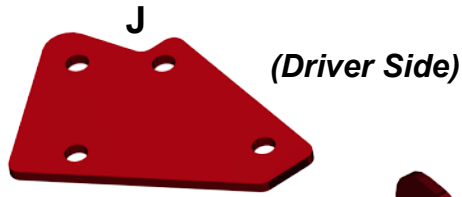

Item	Description
D	Right Rear Outer Bracket
E	Right Rear Inner Bracket
F	Right Rear Clamp Block
G	Left Rear Outer Bracket
H	Left Rear Inner Bracket
J	Left Rear Clamp Block

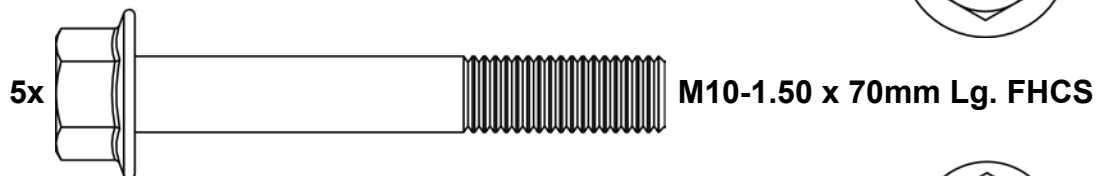

Do not tighten hardware completely unless noted.
Keep all stock hardware for reuse.

FRONT

1. Raise front of machine off ground, secure with jack stands. See Figs. 1 - 1a.
 - Remove Wheels.
 - Disconnect Tie Rods from Spindles.
 - Remove stock Tie Rod Ends from Tie Rods. Install provided Tie Rod Ends (K). Use stock hardware when reinstalling to Spindles.
 - Disconnect Wire Harness from Frame. Reinstall to a convenient location *after* Brackets have been installed.
 - Remove Shocks.
 - Disconnect Differential Vent Tube. Reinstall to a convenient location *after* Brackets have been installed.
2. Install Front Brackets (A)(B) to *outsides* of Frame. See Front Brackets Installation Fig. 2, page 4.
 - Secure Front Brackets (A)(B) with M10-1.50 x 70mm Lg. FHCS, M10-1.50 Nylock Nuts, 30mm Lg. Spacers (U), and 35mm Lg. Spacer (T). See Front Brackets Installation Fig. 2, page 4.
 - Select desired lift setting and reinstall Shocks with M10-1.50 x 70mm Lg. FHCS and M10-1.50 Nylock Nuts. See Front Lift Settings, page 4. **NOTE: If using lowest lift setting, rotate Shocks as shown in "Front Lift Settings".**
4. Reinstall necessary components and tighten all hardware completely.

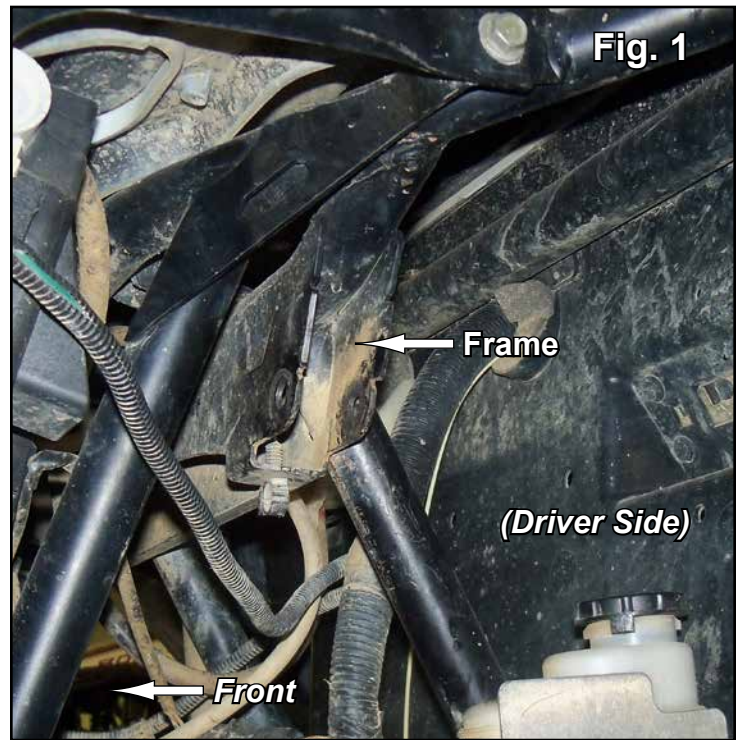
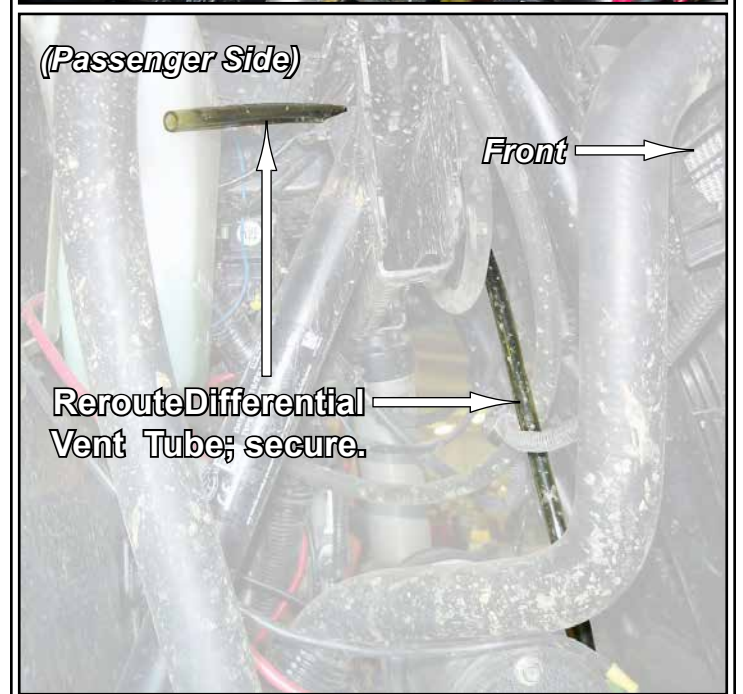
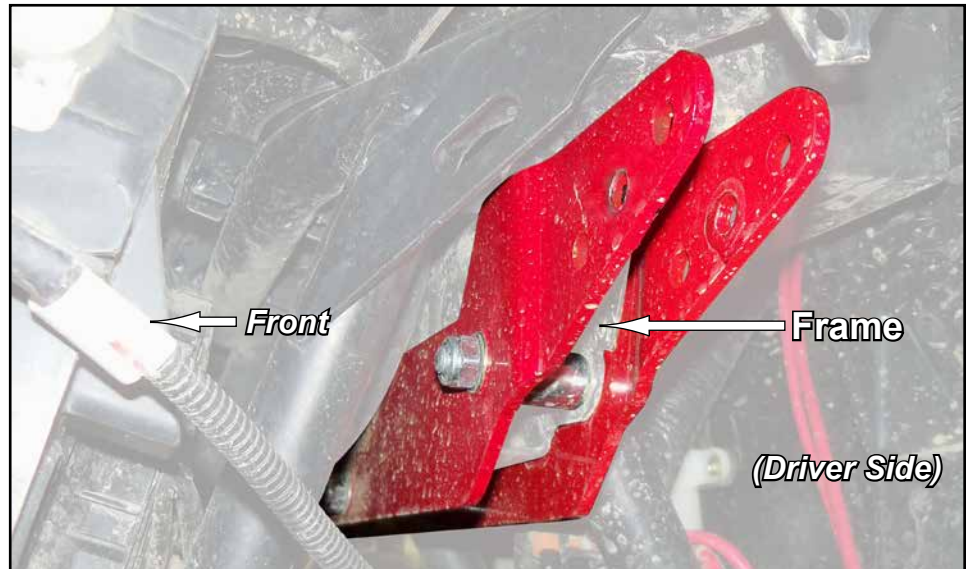
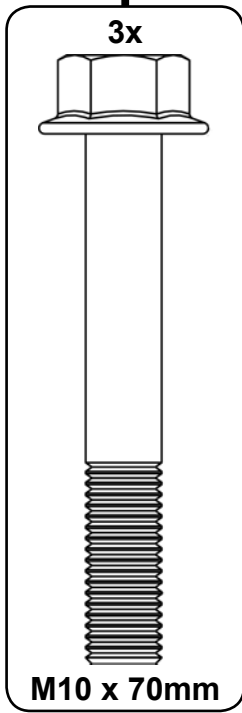
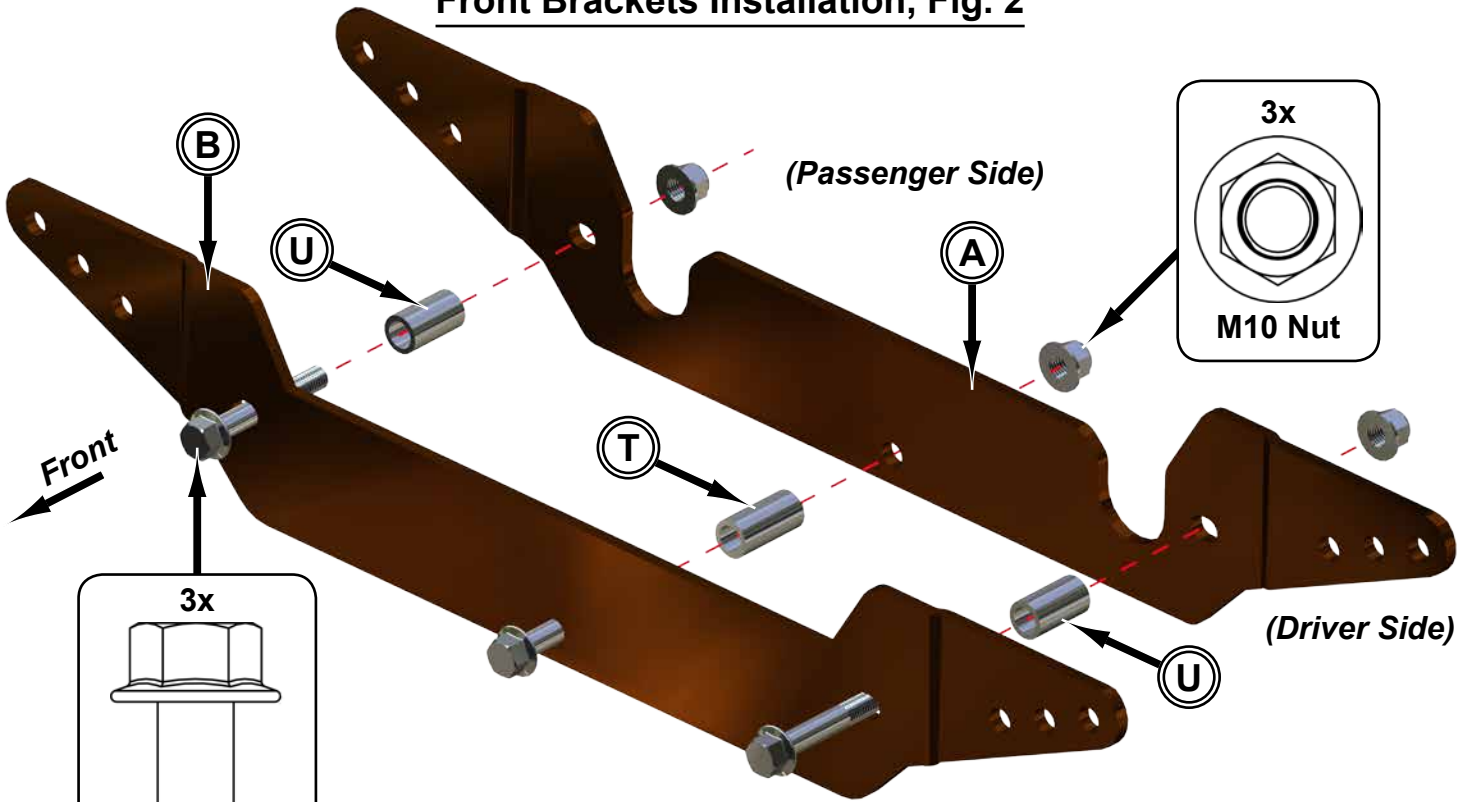

Fig. 1a



Front Brackets Installation, Fig. 2



Shocks must be rotated, as shown, if using lowest lift setting

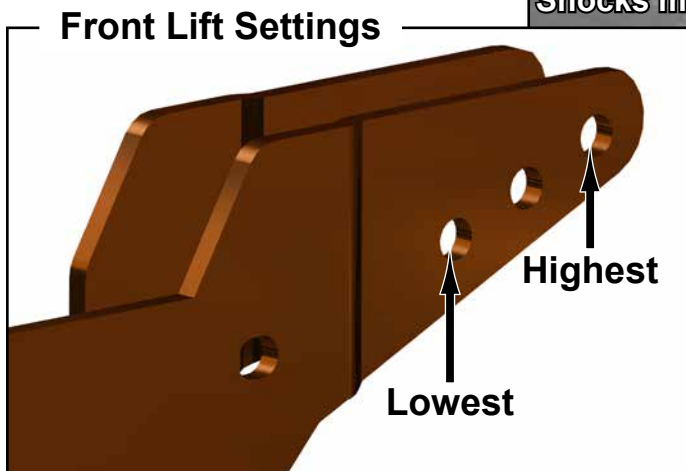

Rear Removal *Keep all stock hardware for reuse.*

1. Raise rear of machine off ground, secure with jack stands, remove Wheels, and Shocks (upper) from Shock Mount. See Fig. 3.
2. Unbolt Sway Bar. See Fig. 3c.
 - Remove RSL's from Spindles. See Fig. 3a.
 - Remove Trailing Arms from Spindles. See Fig. 3b.
3. Install Rear Shims (C). See page 7.
4. Install new Axles; see last page.
 - Reinstall components from Step 2.
 - Tighten hardware completely.

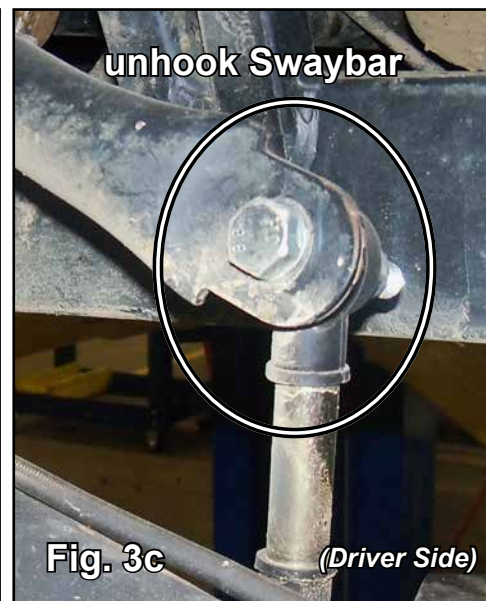
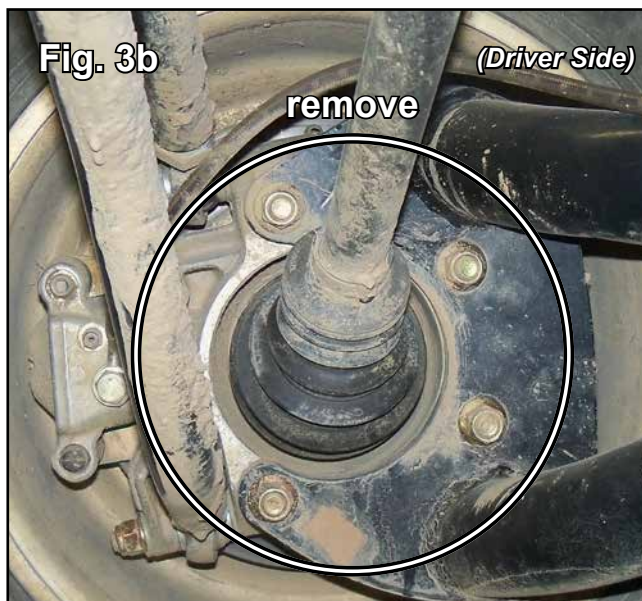
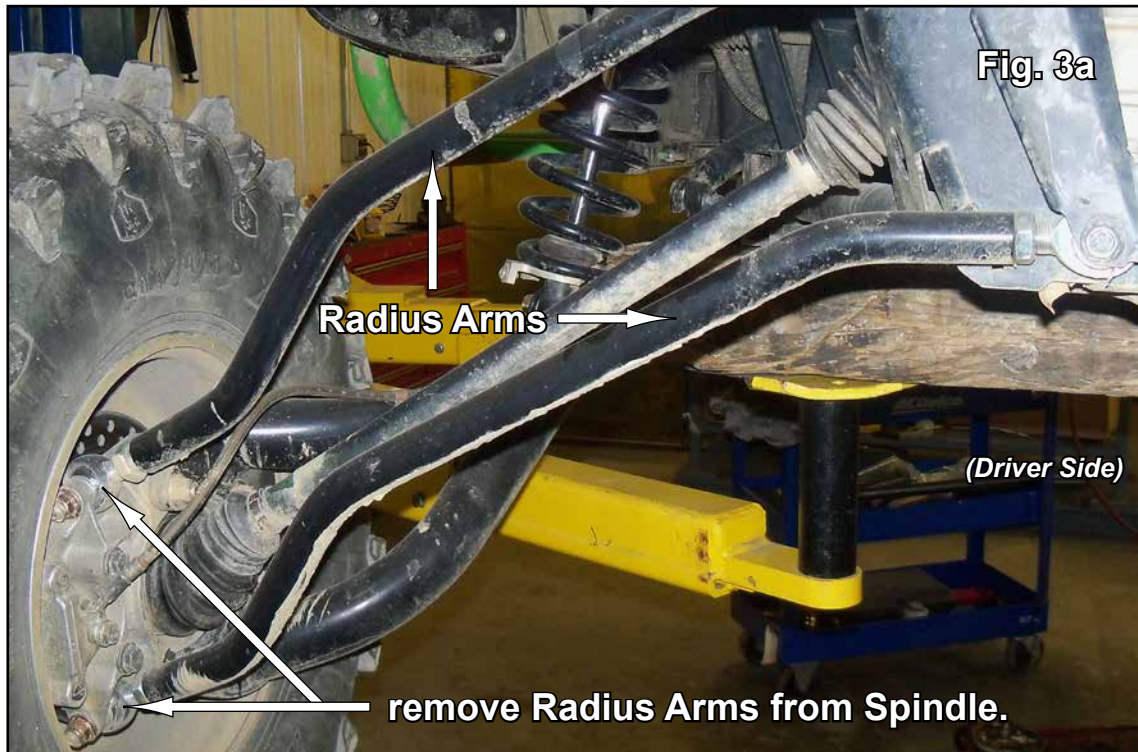
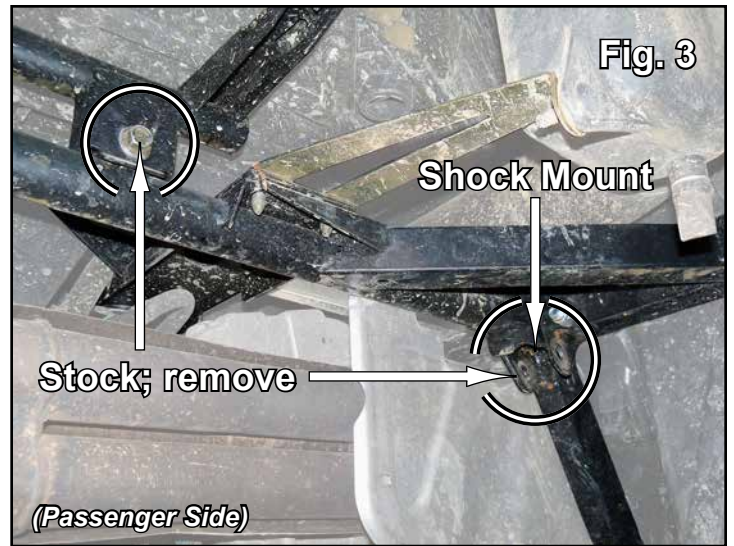

Rear Shim Installation

1. Install Rear Shim (C) between Spindle and Trailing Arm with stock hardware. Bevel will face outside.
- Tighten hardware completely and repeat steps for opposite side.

**Due to machine variations, use of Rear Shims (C) may not be required.
If toe-in occurs after Rear Shims (C) installation; remove.**

Driver Side shown in illustrations

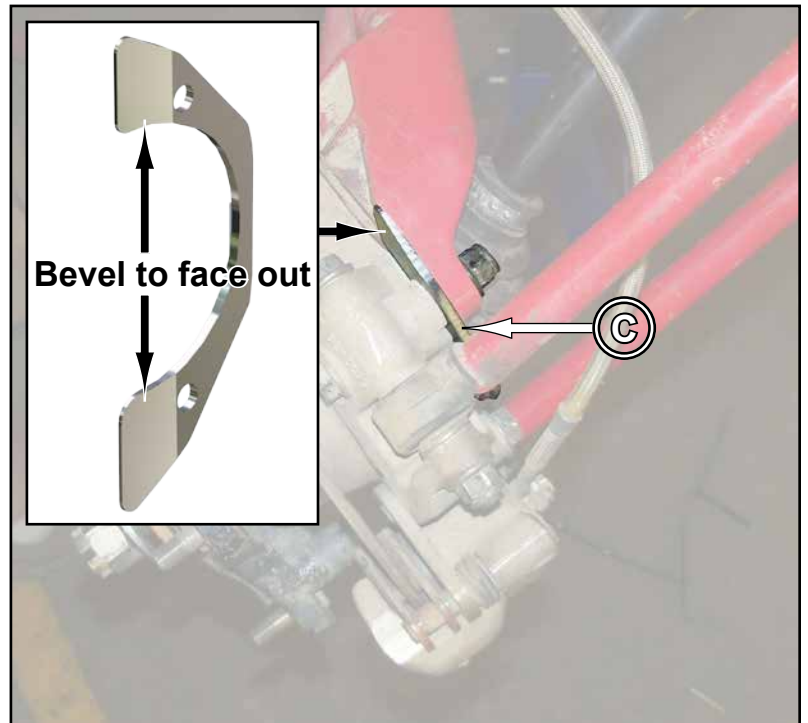
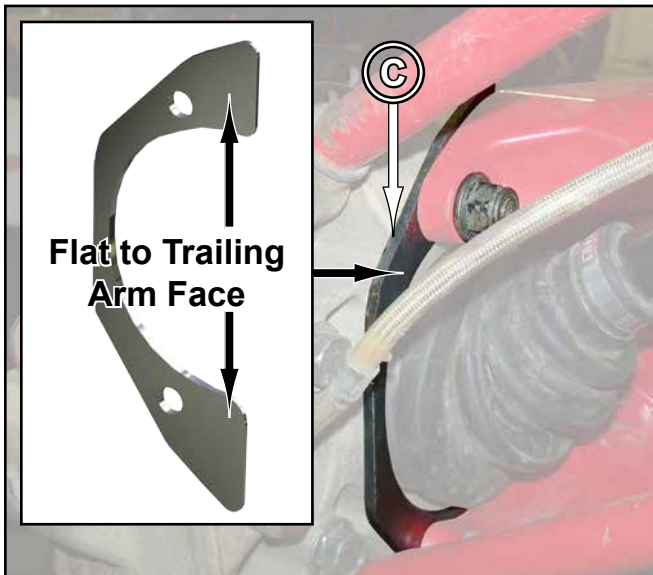
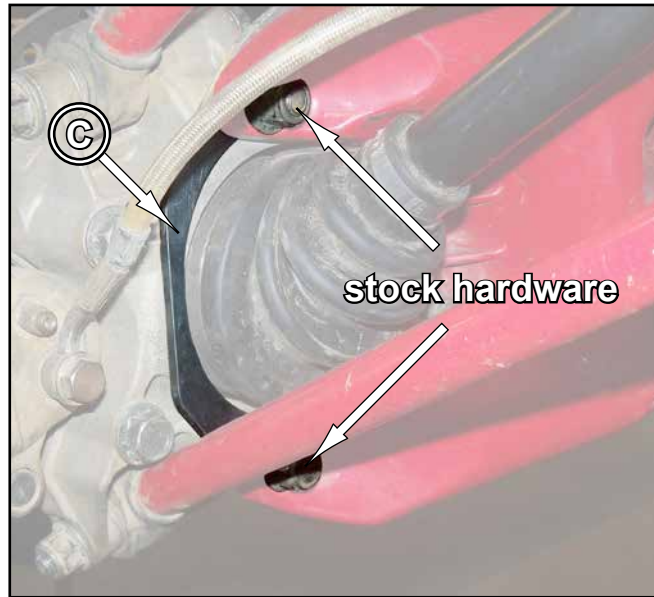

Rear Brackets Installation *Do not tighten hardware completely unless noted.*

1. Install Rear Inner Bracket (H) to **inside** of Shock Mount and Frame. Secure to Frame with M8-1.25 x 30mm Lg. Self Tapping Bolt. Install 25mm Lg. Spacer (V) at this time. See Step 1 on page 8.
2. Rear Outer Bracket (G) to **outside** of Shock Mount. Insert Shock at this time and secure Rear Inner and Outer Brackets (H)(G) with M12-1.75 x 55mm Lg. FHCS and M12-1.75 Nylock Nut. See Step 2 on page 8.
3. Install Left Rear Clamp Block (J) over Frame and to Rear Outer Bracket (G) with M8-1.25 x 60mm Lg. FHCS and M8-1.25 Nylock Nuts. See Step 3 on page 8.
 - Secure Shock with M12-1.75 x 55mm Lg. FHCS and M12-1.75 Nylock Nut. See Step 3 on page 8.
 - Join Rear Inner and Outer Brackets (H)(G) with M8-1.25 x 25mm Lg. FHCS and M8-1.25 Nylock Nuts. See Step 3 on page 8.
4. Tighten hardware completely and repeat steps for opposite side.

- Rear Bracket installation illustrations on page 8 -

Rear Brackets Reference (Passenger Side shown)

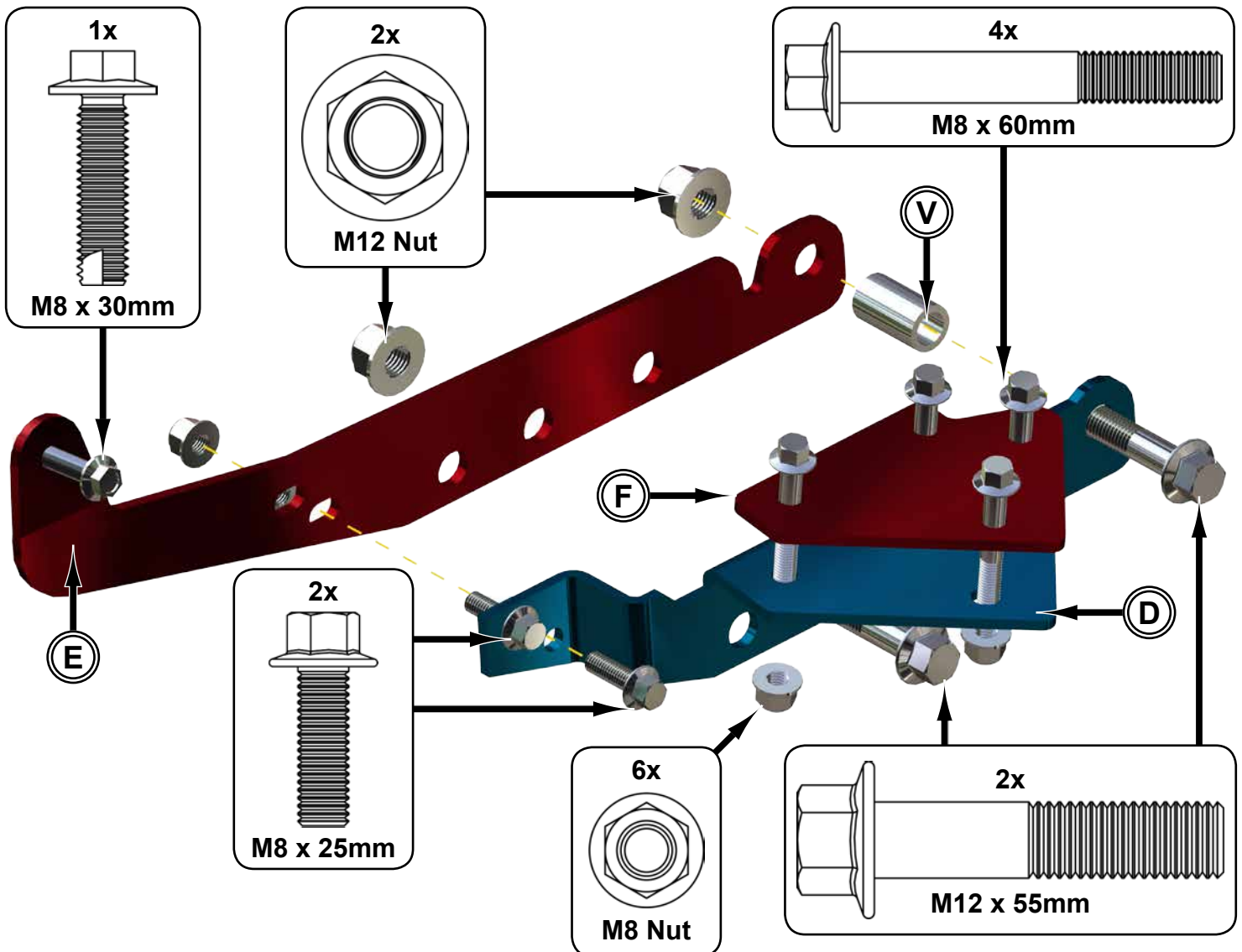

Rear Brackets Installation continued

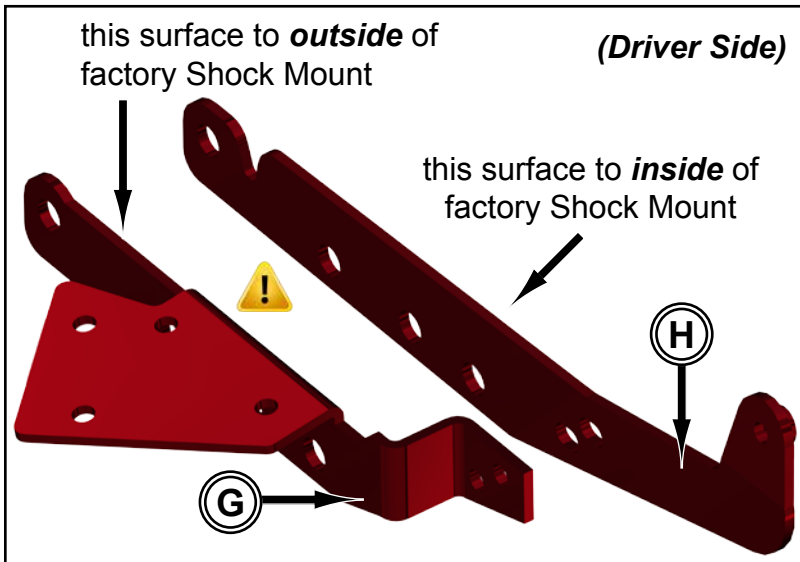

Driver Side shown

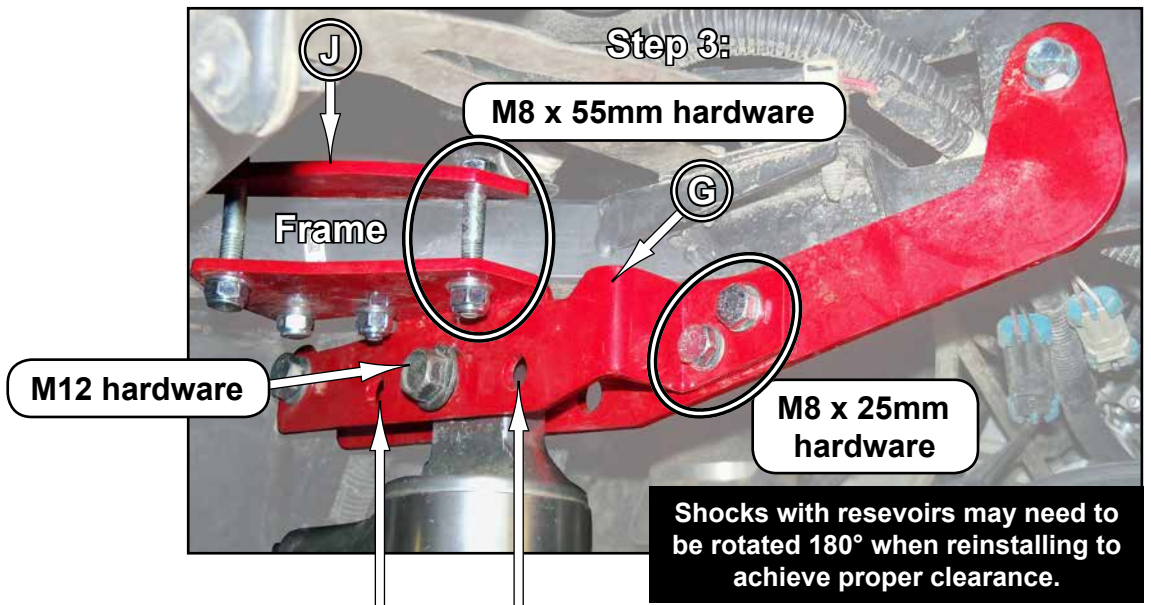
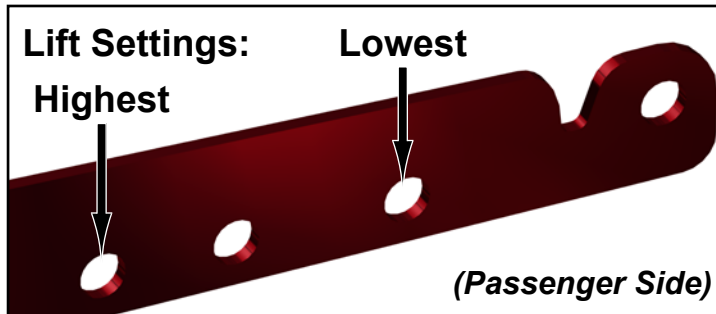
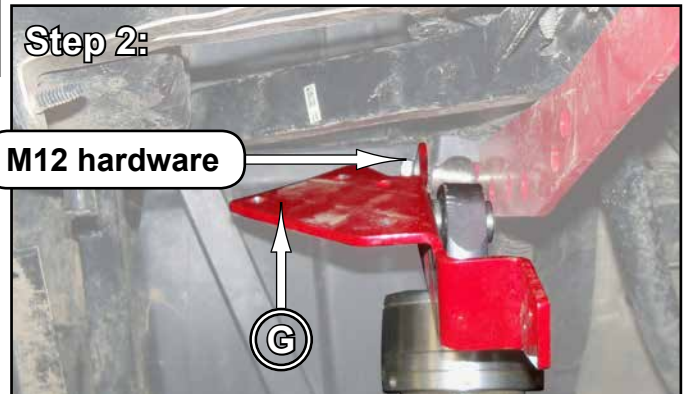
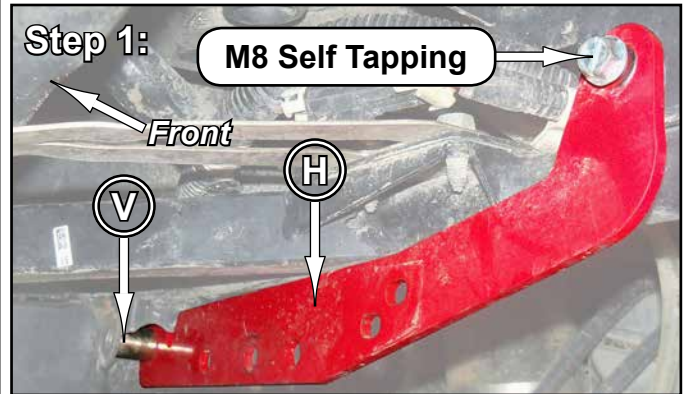

After Shocks have been installed, add hardware to remaining holes in Rear Brackets.

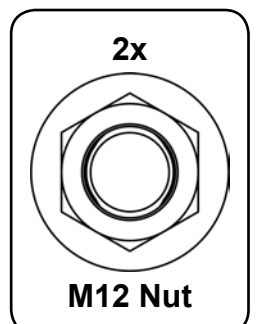
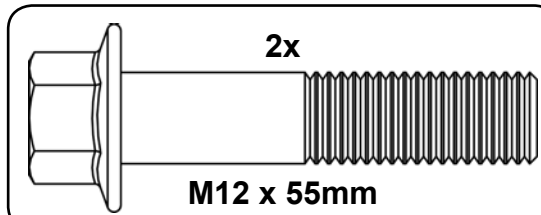
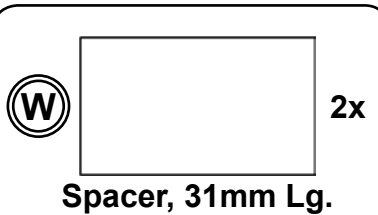

Trailing Arms must be trimmed. Rear Axle Boots will interfere.



Liability Statement

SuperATV's® products are designed to best fit user's ATV/UTV under stock conditions. Adding, modifying, or fabricating any factory or aftermarket parts will void any warranty provided by SuperATV® and is not recommended. SuperATV's® products could interfere with other aftermarket accessories. If user has aftermarket products on machine, contact SuperATV® to verify that they will work together.

Although SuperATV® has thousands of satisfied customers, user should be aware that installing lift kits, long travel, or suspension kits, tires, etc. will change the ride of machine and may increase maintenance and part wear. Operating any off-road machine while, or after, consuming alcohol and/or drugs increases risk of bodily harm or death. No warranty or representation is made as to this product's ability to protect user from severe injury or death. SuperATV® urges operators and occupants to wear a helmet and appropriate riding gear at all times.

By purchasing and installing SuperATV® products, user agrees that should damages occur, SuperATV® will not be held responsible for loss of time, use, labor fees, replacement parts, or freight charges. SuperATV®, nor any 3rd party, will not be held responsible for any direct, indirect, incidental, special, or consequential damages that result from any product purchased from SuperATV®. The total liability of seller to user for all damages, losses, and causes of action, if any, shall not exceed the total purchase price paid for the product that gave rise to the claim.

SuperATV® will warranty only parts provided by SuperATV®. Any damage or problems with OEM housings, bearings, seals, or other manufacturers' products will not be covered by SuperATV®. SuperATV® parts and products are not warranted if item was not installed properly, misused, or modified.

Installing, adding, modifying, or fabricating any factory or aftermarket product to your ATV/UTV may violate certain local, state, and federal laws. Be advised that laws vary depending on town, city, county, state, etc. Use of certain products on public streets, roads, or highways may be in violation law. The Buyer is solely and exclusively legally and personally responsible for any violation of the law by the installation or use of the product. You must abide by all local, state, and federal laws, including but not limited to vehicle safety, traffic laws, and ordinances. It is your responsibility to know the laws and how they apply to you.

The Buyer is responsible to fully understand the capability and limitations of his/her vehicle according to manufacturer specifications, warnings and instructions and agrees to hold SuperATV® harmless from any damage resulting from failure to adhere to such specifications, warnings and/ or instructions. The Buyer is also responsible to obey all applicable federal, state, and local laws and ordinances when operating his/her vehicle while using this product, and the Buyer agrees to hold SuperATV® harmless from any violation thereof.