

Item	Description
A	Right Front Bracket
B	Left Front Bracket
C	Right Rear Bracket
D	Left Rear Bracket
E	Cross Brace

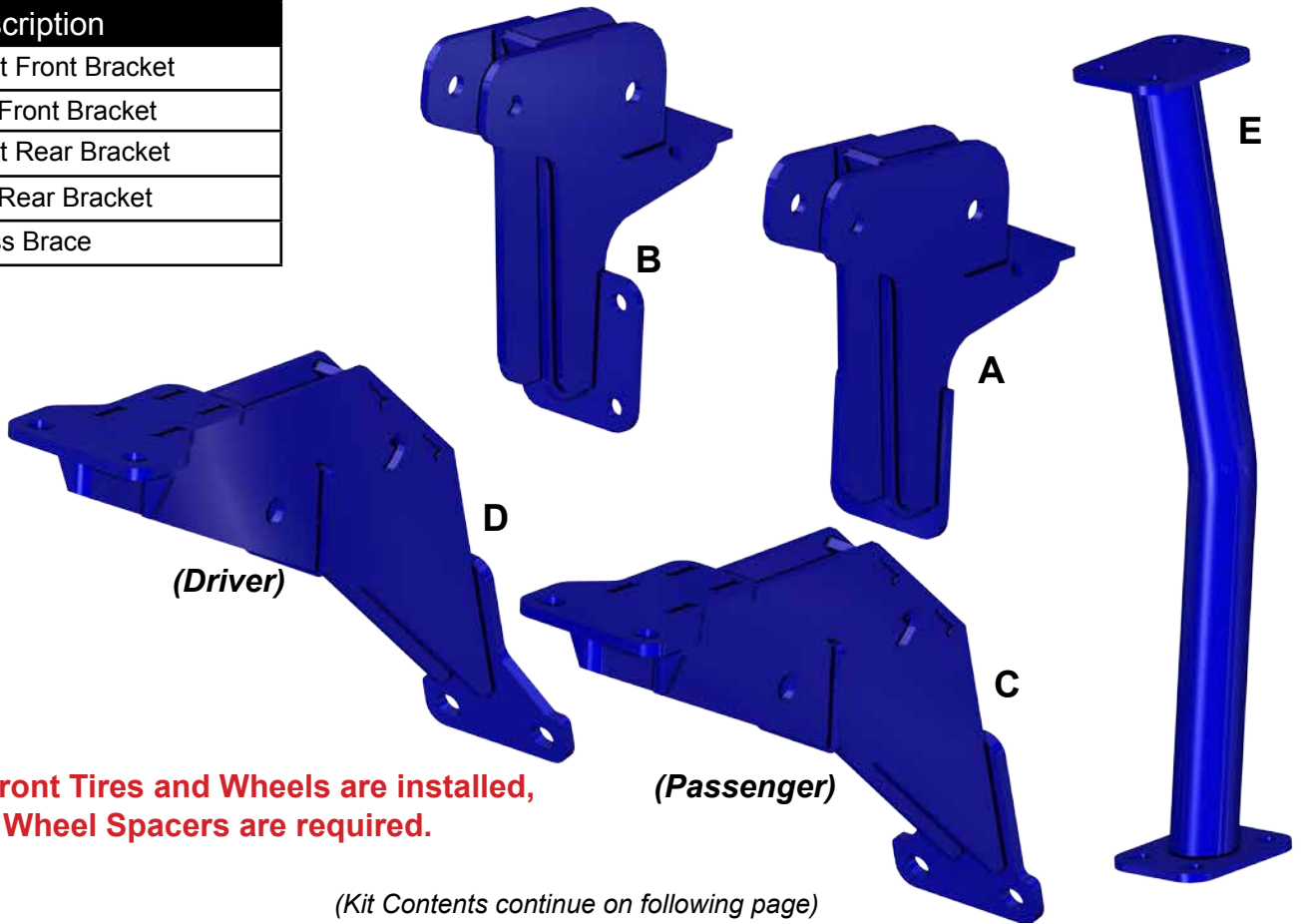

**If stock Front Tires and Wheels are installed,
 1" Wheel Spacers are required.**

(Kit Contents continue on following page)

Liability Statement

SuperATV's® products are designed to best fit user's ATV/UTV under stock conditions. Adding, modifying, or fabricating any factory or aftermarket parts will void any warranty provided by SuperATV® and is not recommended. SuperATV's® products could interfere with other aftermarket accessories. If user has aftermarket products on machine, contact SuperATV® to verify that they will work together.

Although SuperATV® has thousands of satisfied customers, user should be aware that installing lift kits, long travel, or suspension kits, tires, etc. will change the ride of machine and may increase maintenance and part wear. Operating any off-road machine while, or after, consuming alcohol and/or drugs increases risk of bodily harm or death. No warranty or representation is made as to this product's ability to protect user from severe injury or death. SuperATV® urges operators and occupants to wear a helmet and appropriate riding gear at all times.

By purchasing and installing SuperATV® products, user agrees that should damages occur, SuperATV® will not be held responsible for loss of time, use, labor fees, replacement parts, or freight charges. SuperATV®, nor any 3rd party, will not be held responsible for any direct, indirect, incidental, special, or consequential damages that result from any product purchased from SuperATV®. The total liability of seller to user for all damages, losses, and causes of action, if any, shall not exceed the total purchase price paid for the product that gave rise to the claim.

SuperATV® will warranty only parts provided by SuperATV®. Any damage or problems with OEM housings, bearings, seals, or other manufacturers' products will not be covered by SuperATV®. SuperATV® parts and products are not warranted if item was not installed properly, misused, or modified.

Installing, adding, modifying, or fabricating any factory or aftermarket product to your ATV/UTV may violate certain local, state, and federal laws. Be advised that laws vary depending on town, city, county, state, etc. Use of certain products on public streets, roads, or highways may be in violation law. The Buyer is solely and exclusively legally and personally responsible for any violation of the law by the installation or use of the product. You must abide by all local, state, and federal laws, including but not limited to vehicle safety, traffic laws, and ordinances. It is your responsibility to know the laws and how they apply to you.

The Buyer is responsible to fully understand the capability and limitations of his/her vehicle according to manufacturer specifications, warnings and instructions and agrees to hold SuperATV® harmless from any damage resulting from failure to adhere to such specifications, warnings and/ or instructions. The Buyer is also responsible to obey all applicable federal, state, and local laws and ordinances when operating his/her vehicle while using this product, and the Buyer agrees to hold SuperATV® harmless from any violation thereof.

Need help with your installation?



sales@superatv.com



www.superatv.com



1-855-743-3427



8:00am - 9:00pm EST M-Th
 8:00am - 7:00pm EST Friday
 9:00am - 2:00pm EST Saturday

Read instructions and view illustrations before beginning.

Thank You

For Choosing



(Kit Contents continued)

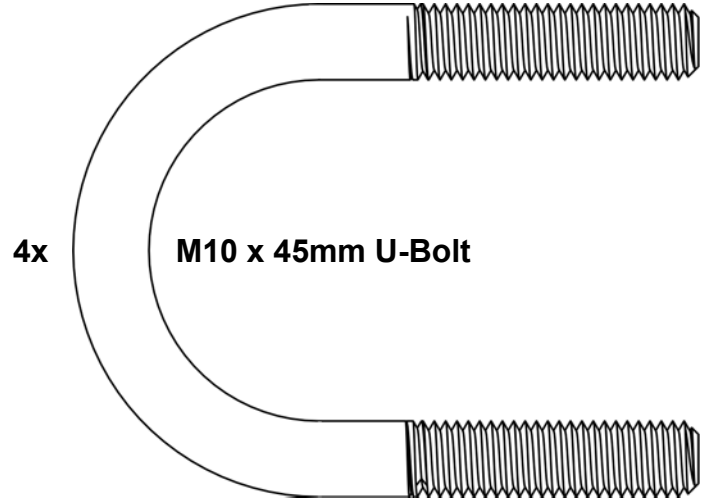
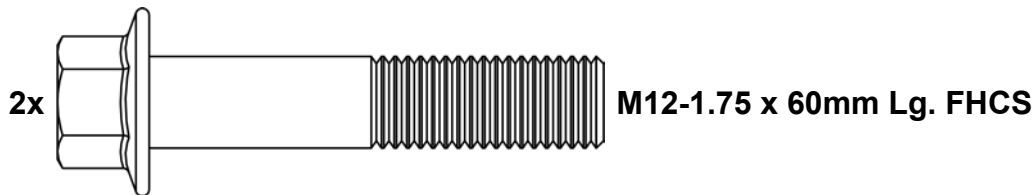
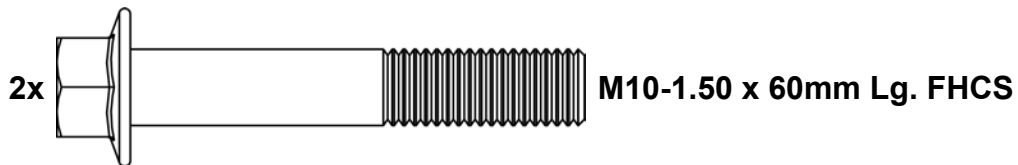
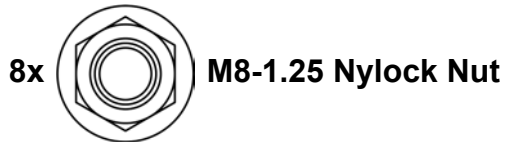

Remove components shown from each side of machine. Keep all components.

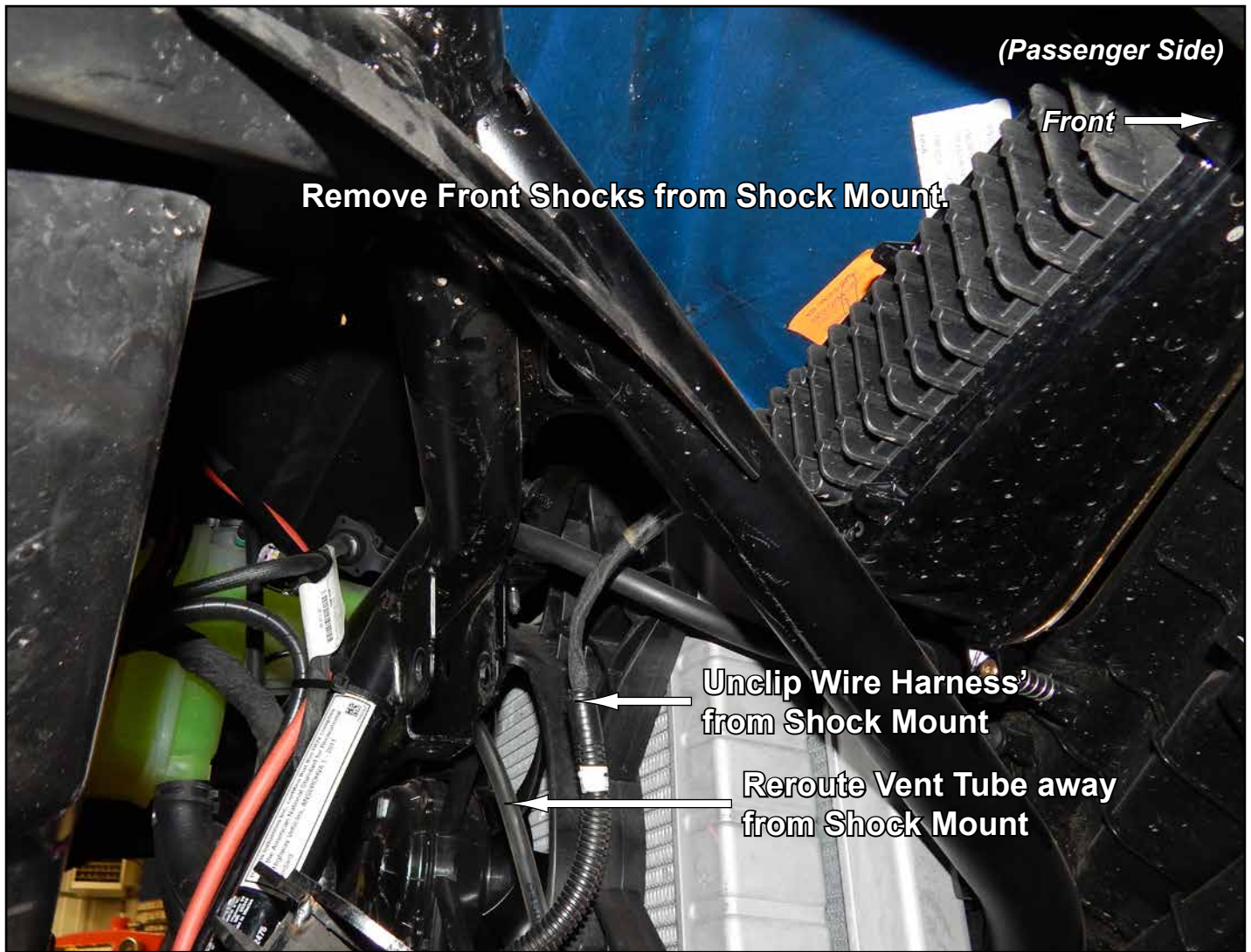

- Remove Front Axles if SuperATV A-Arms, p/n AA-P-RZRXP15-WC, are installed.

Do not tighten hardware completely unless noted.

- Install Right Front Bracket (A) to Cross Brace (E) with hardware shown.

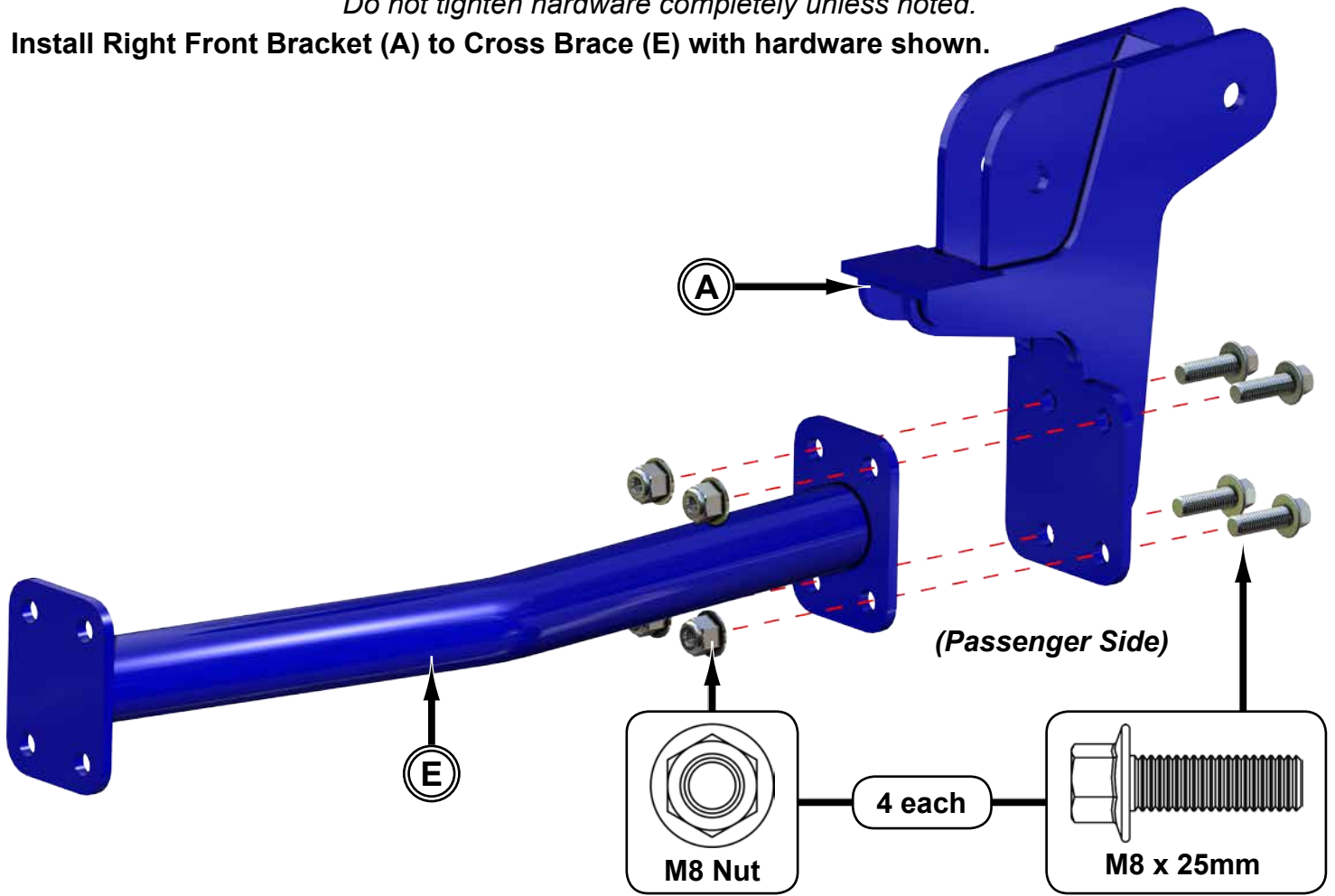

- Insert Right Front Bracket (A) - Cross Brace (E) assembly into passenger side of machine.
- Secure Right Front Bracket (A) to Shock Mount with stock Shock hardware.

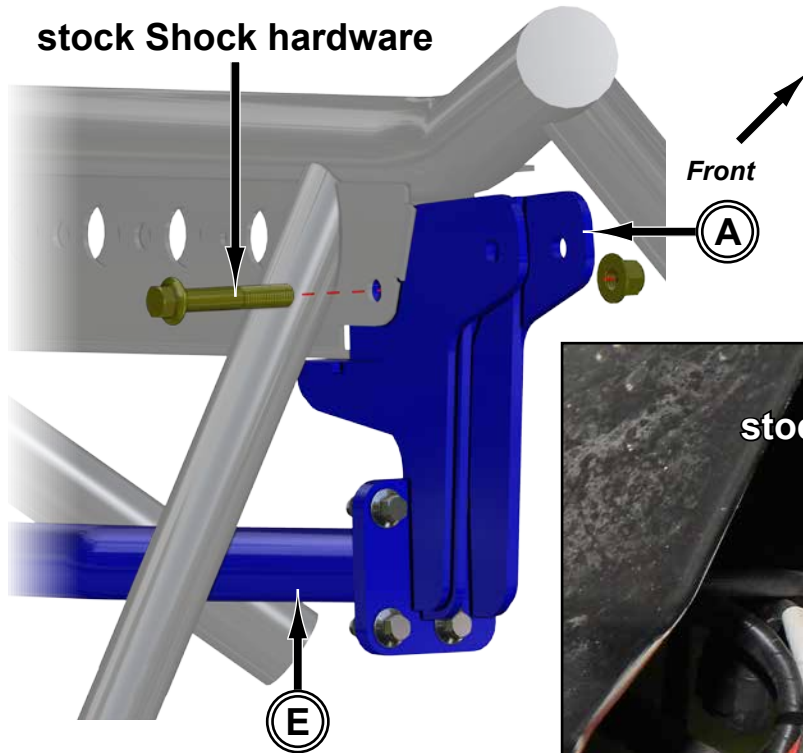

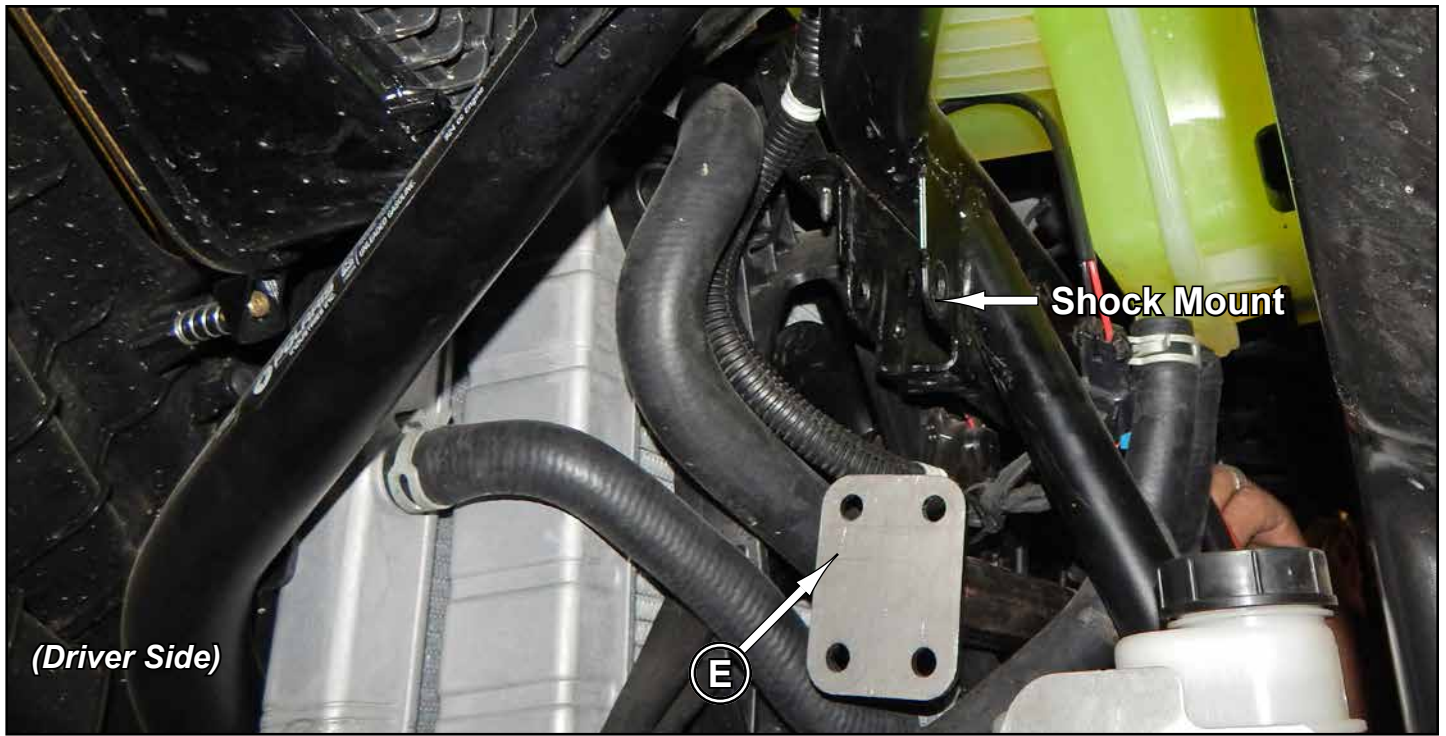

- Secure Left Front Bracket (B) to Cross Brace (E) with hardware shown.

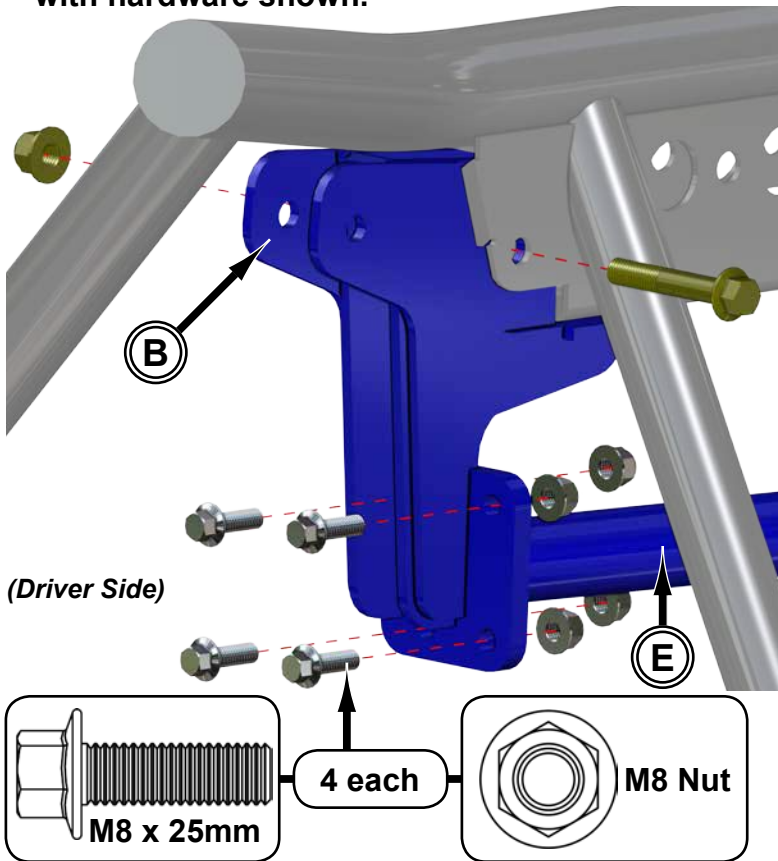

- Secure Left Front Bracket (B) to Shock Mount with stock Shock hardware.



If Left Front Bracket (B) will not fit into Shock Mount, see following page.

- Secure Shocks to new Brackets with provided M10-1.50 x 60 FHCS and M10-1.50 Nylock Nuts.
- Install provided Front Axles if SuperATV A-Arms, p/n AA-P-RZRXP15-WC, are installed.
- Tighten all hardware completely.

- To get Left Front Bracket (B) into Shock Mount, hit with a mallet until installed.
- *In some instances Left Front Bracket (B) will have to be ground slightly in area shown, on both sides, for proper fitment.*



Remove components shown from each side of machine. *Keep all components.*

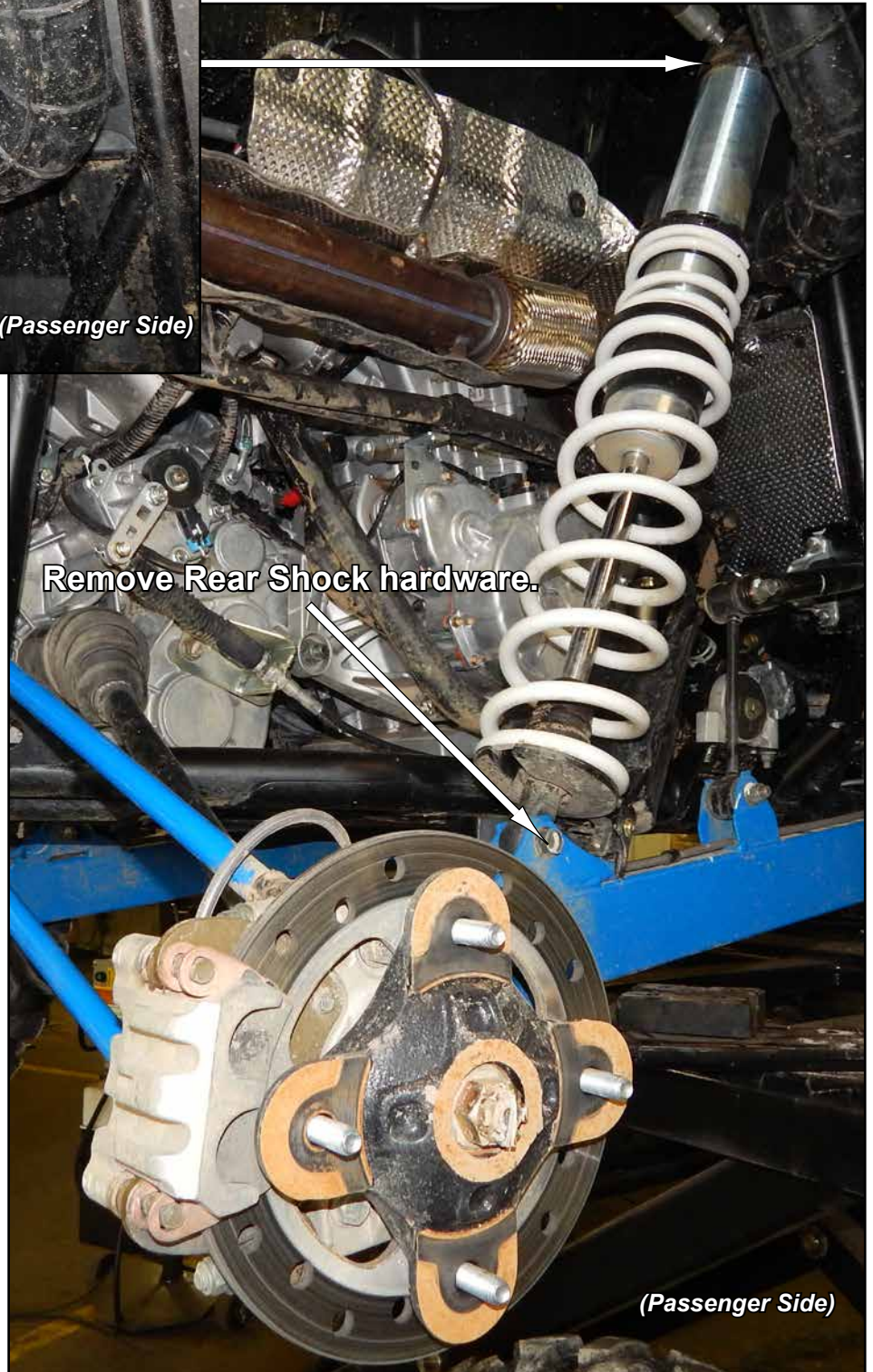

- Install Left Rear Bracket (D) to stock Shock Mount with stock Shock hardware; secure U-Bolts first.

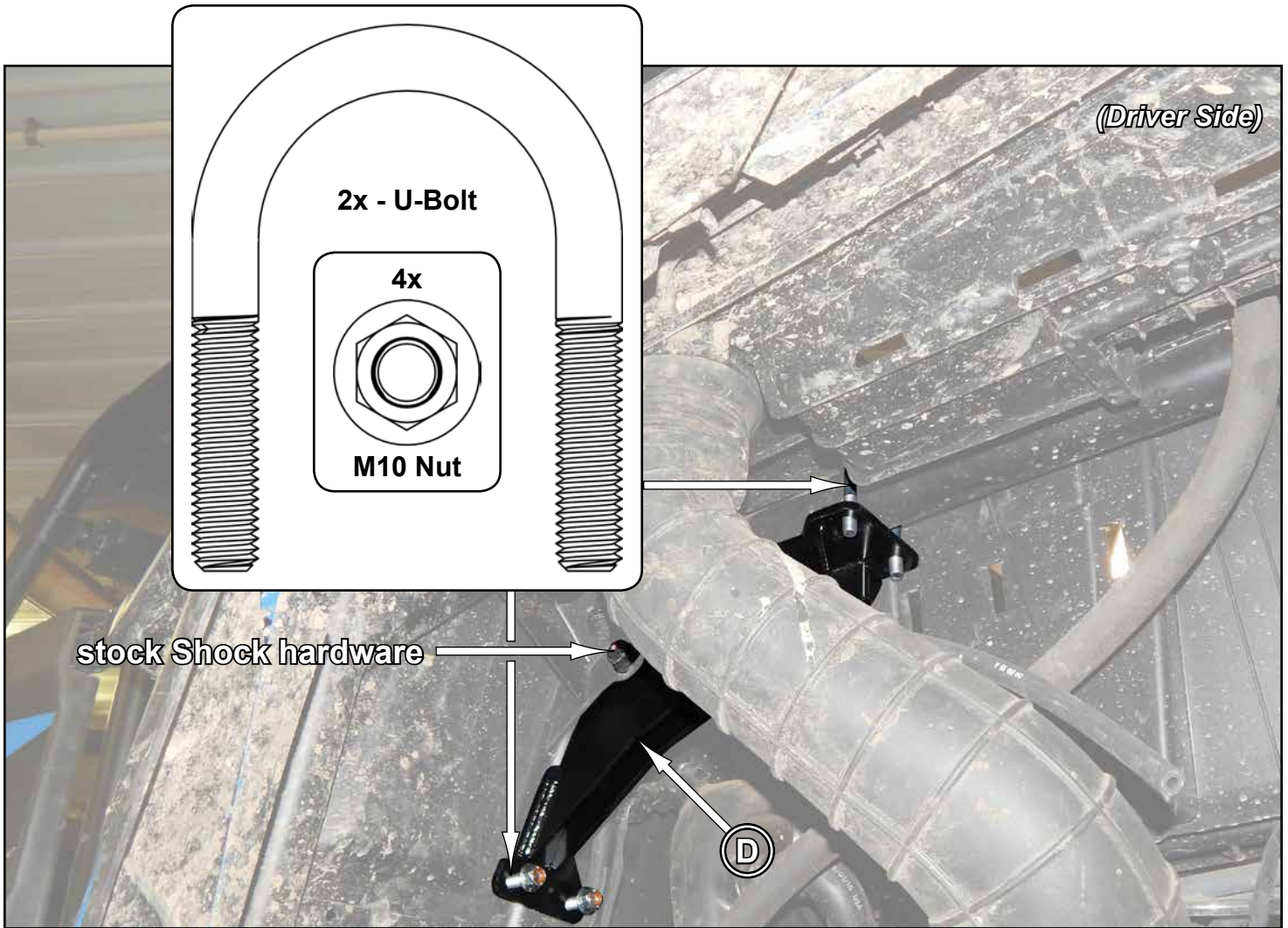

- Install Shock to Left Rear Bracket (D) with hardware shown.
- Use stock hardware when securing Shock to Trailing Arm.

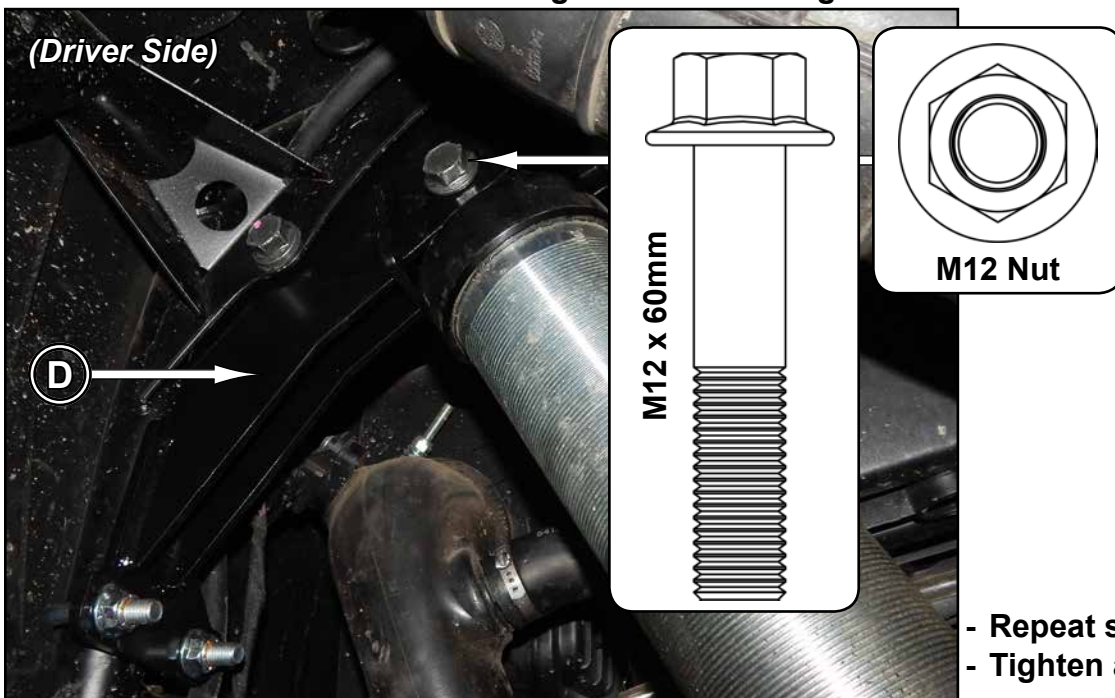

- Repeat steps for opposite side.
- Tighten all hardware completely.

Rear Passenger Side only:



2x
Place onto U-Bolts;
Passenger side only



Walker Evans shocks must
be flipped as shown



(Passenger Side)

If stock Front Tires and Wheels are installed, 1" Wheel Spacers are required.

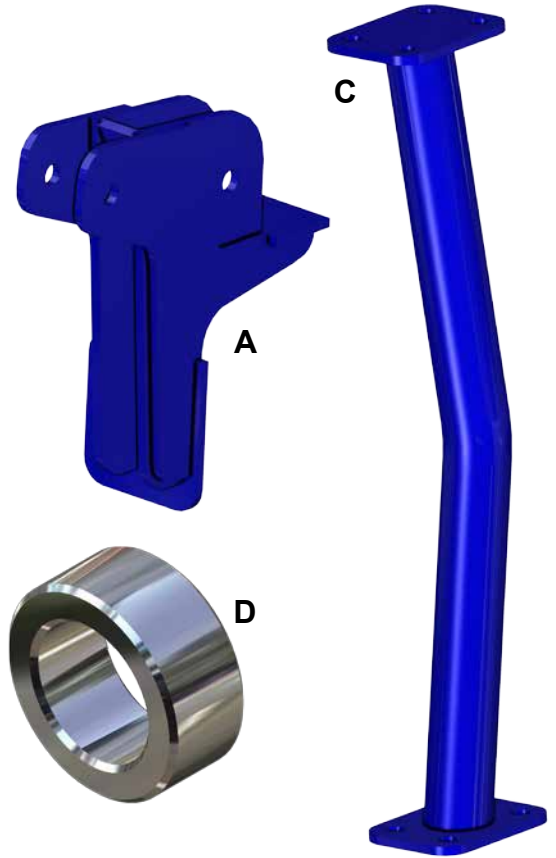
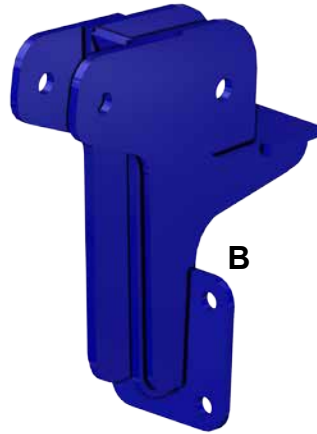

Item	Description
A	Right Front Bracket
B	Left Front Bracket
C	Cross Brace
D	Rear Spring Spacer x 2

SuperATV strongly recommends using a Spring Compressor when removing and installing Springs.



Need help with your installation?

 sales@superatv.com
 www.superatv.com

 1-855-743-3427
  8:00am - 9:00pm EST M-Th
 8:00am - 7:00pm EST Friday
 9:00am - 2:00pm EST Saturday

Read instructions and view illustrations before beginning.

Thank You
For Choosing
SUPERATV.COM[®]

Liability Statement

SuperATV's® products are designed to best fit user's ATV/UTV under stock conditions. Adding, modifying, or fabricating any factory or aftermarket parts will void any warranty provided by SuperATV® and is not recommended. SuperATV's® products could interfere with other aftermarket accessories. If user has aftermarket products on machine, contact SuperATV® to verify that they will work together.

Although SuperATV® has thousands of satisfied customers, user should be aware that installing lift kits, long travel, or suspension kits, tires, etc. will change the ride of machine and may increase maintenance and part wear. Operating any off-road machine while, or after, consuming alcohol and/or drugs increases risk of bodily harm or death. No warranty or representation is made as to this product's ability to protect user from severe injury or death. SuperATV® urges operators and occupants to wear a helmet and appropriate riding gear at all times.

By purchasing and installing SuperATV® products, user agrees that should damages occur, SuperATV® will not be held responsible for loss of time, use, labor fees, replacement parts, or freight charges. SuperATV®, nor any 3rd party, will not be held responsible for any direct, indirect, incidental, special, or consequential damages that result from any product purchased from SuperATV®. The total liability of seller to user for all damages, losses, and causes of action, if any, shall not exceed the total purchase price paid for the product that gave rise to the claim.

SuperATV® will warranty only parts provided by SuperATV®. Any damage or problems with OEM housings, bearings, seals, or other manufacturers' products will not be covered by SuperATV®. SuperATV® parts and products are not warranted if item was not installed properly, misused, or modified.

Installing, adding, modifying, or fabricating any factory or aftermarket product to your ATV/UTV may violate certain local, state, and federal laws. Be advised that laws vary depending on town, city, county, state, etc. Use of certain products on public streets, roads, or highways may be in violation law. The Buyer is solely and exclusively legally and personally responsible for any violation of the law by the installation or use of the product. You must abide by all local, state, and federal laws, including but not limited to vehicle safety, traffic laws, and ordinances. It is your responsibility to know the laws and how they apply to you.

The Buyer is responsible to fully understand the capability and limitations of his/her vehicle according to manufacturer specifications, warnings and instructions and agrees to hold SuperATV® harmless from any damage resulting from failure to adhere to such specifications, warnings and/ or instructions. The Buyer is also responsible to obey all applicable federal, state, and local laws and ordinances when operating his/her vehicle while using this product, and the Buyer agrees to hold SuperATV® harmless from any violation thereof.

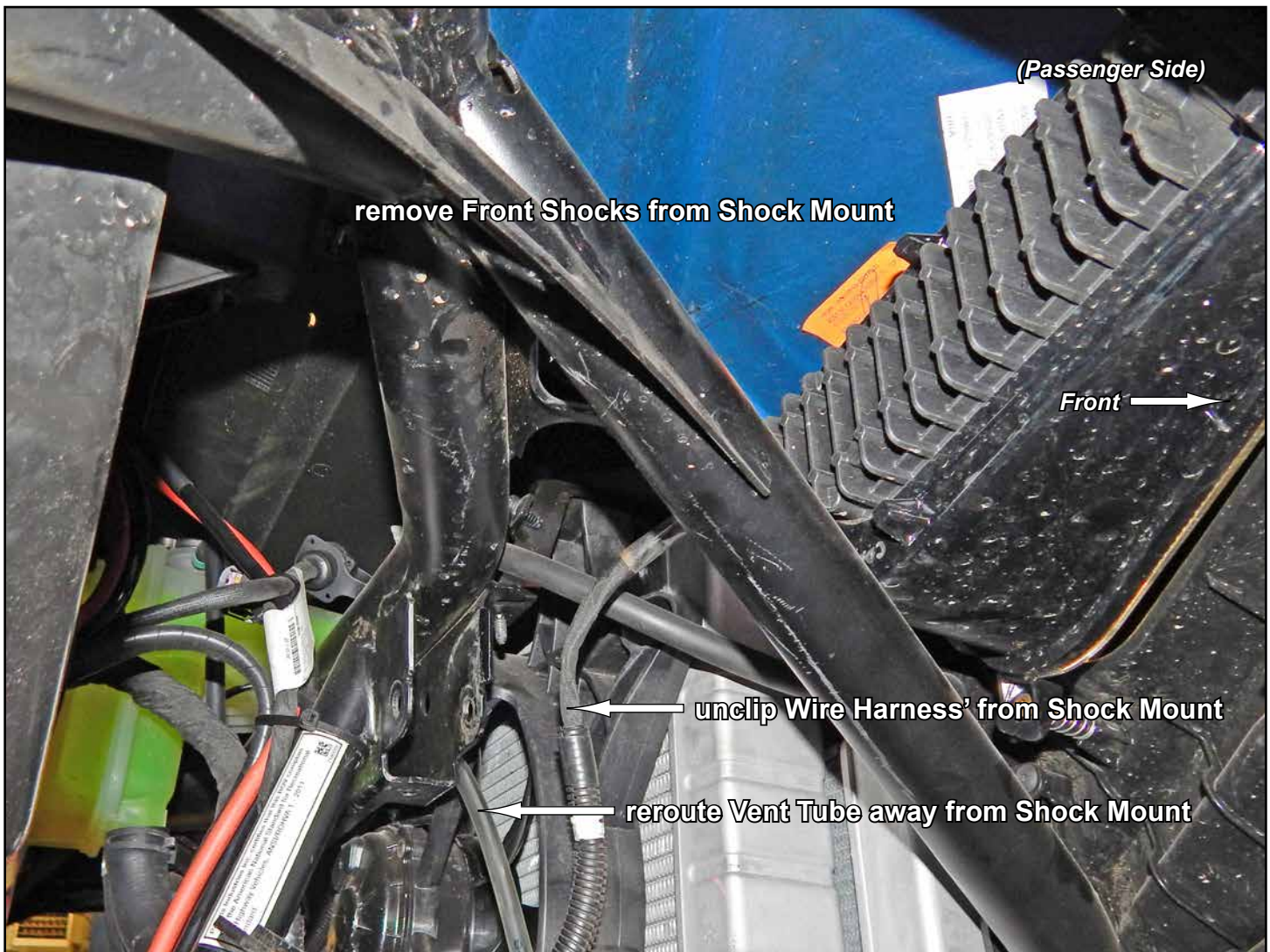



Do not tighten hardware completely unless noted.

- Install Right Front Bracket (A) to Cross Brace (C) with hardware shown.

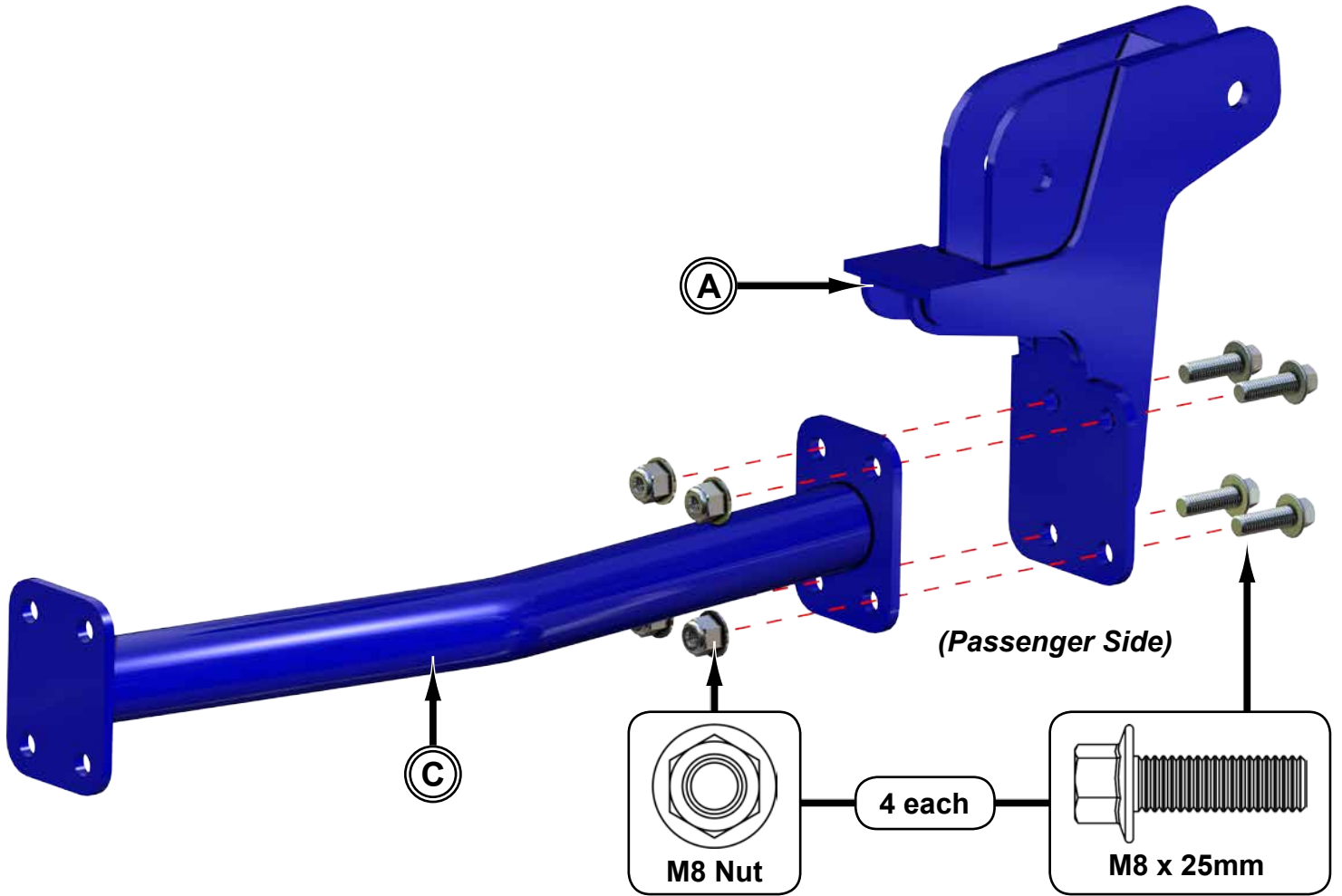

- Insert Right Front Bracket (A) - Cross Brace (C) assembly into passenger side of machine.
- Secure Right Front Bracket (A) to Shock Mount with stock Shock hardware.





(Driver Side)

- Secure Left Front Bracket (B) to Cross Brace (E) with hardware shown.
- Secure Left Front Bracket (B) to Shock Mount with stock Shock hardware.

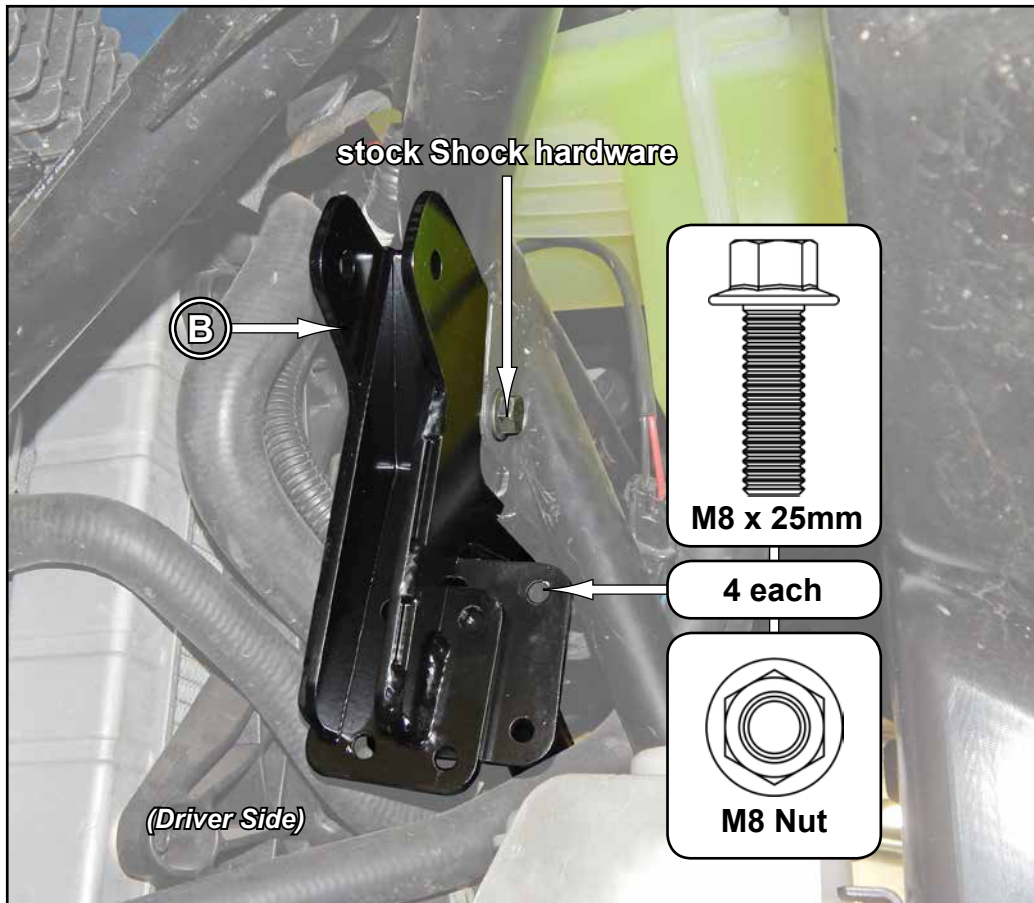

(Driver Side)

- Secure Shocks to new Brackets with provided M10 hardware.
- Tighten all hardware completely.

Rear Spring Spacer installation



Rear Spring Spacer installation continued



- Reinstall Spring, Retainer, and Guard.



- Repeat steps for opposite Shock.
- Reinstall Shocks with stock hardware.
- Tighten all hardware completely.